

Ag Leader®



OnTrac3

Operators Manual

PN2006236—ENG REV. B

OnTrac3

- IMPORTANT INFORMATION 1
 - TRADEMARK 1
- TECHNICAL SUPPORT 1
- LEGAL DISCLAIMER 1
- SAFETY INFORMATION 1
 - WARNING ALERTS 1
 - CAUTION ALERTS 2
- INSTALLATION 2**
 - OVERVIEW 2
 - DISPLAY KITS 2
 - GPS/GNSS SMART ANTENNA KIT 3
 - ECU-S1 KIT 3
 - VEHICLE INSTALLATION KITS 3
 - ACCESSORY KITS 4
- TRANSFERRING SYSTEM FROM VEHICLE TO VEHICLE 4**
 - REMOVING SYSTEM FROM A VEHICLE 4
 - INSTALLING SYSTEM ON TO VEHICLE 5
- ECU-S1 LED DIAGNOSTICS 5**
 - ACCESSING AUTOSTEER SETUP SCREENS 6
- VEHICLE TAB 7**
 - STANDARD SETUP WIZARD STEPS 7
 - Select Vehicle Type 8
 - Select Vehicle Make 8
 - Select Vehicle Model 8
 - Select Controller Type 8
 - Wheel Base 9
 - Antenna Fore/Aft 9
 - Antenna Lateral Offset 10
 - Antenna Height 11
 - ECU-S1 Fore/Aft 11
 - ECU-S1 Lateral Offset 12
 - ECU-S1 Height 12
 - ECU-S1 Orientation 13
 - Get Orientations 13
 - Enter Angles 14
 - Manual Steering Override 15
 - Kickout 15
 - Manual Steering Override Auto Calibrate 16**
 - MDU-G4 Auto Calibrate 16**
 - AUTO CALIBRATE 16**
 - COMMON CALIBRATION STEPS 17**
 - Compass Calibration 17**
 - Wait For Heading 17**
 - Compass Verification Warming Up 18**
 - Tilt Zero 18**
 - Initial Direction 18**
 - Opposite Direction 18**
 - Mechanical Steering Unit (MDU-G4) 18**
 - ADJUST ANTENNA LATERAL OFFSET 19**
 - MANAGE VEHICLE 20**
 - SELECT 20
 - EDIT 21
 - DELETE 22

EXPORT/IMPORT	22
EXPORT TO DISPLAY USB	23
IMPORT FROM DISPLAY USB	23
AUTO CALIBRATE	24
STEERING ADJUST	24
STEERING COMPONENTS	25
ECU-S1	25
MANUAL STEERING OVERRIDE	25
MDU-G4	25
MDU ACTUATOR	26
REMOTE SWITCH	26
ECU SENSORS	26
SYSTEM TAB	27
SYSTEM HEALTH	27
MANAGE SETTINGS	28
LOG FILES	28
Copy to Display USB	29
Delete	29
DATABASE	30
Backup to USB	30
Restore from Display USB	30
RESET FACTORY DEFAULT	32
Reset	33
SHUTDOWN DELAY	33
HISTORY FILES	33
ACCESSORIES	34
REMOTE SWITCH ENGAGE	34
ENABLE (DISABLE)	34
REMOTE SWITCH DISENGAGE	34
ENABLE (DISABLE)	35
TECHNICIAN	35
SOFTWARE UPGRADE	35
UPGRADE PROCEDURE	35
SYSTEM LOG	37
GPS TAB	37
GPS DIAGNOSTICS	37
GENERAL	37
NMEA MESSAGES	38
NMEA STATUS	38
FIX DETAILS	38
GPS PRECISION SETTINGS	39
RELAX DOP FOR STEERING	39
NMEA OUT	39
NMEA-OUT MESSAGES	39
MESSAGES CONFIGURATION	40
NMEA-OUT PORT CONFIGURATION	40
PORT CONFIGURATION	41
CONNECTIONS TAB	41
WIFI	41
MY ACCOUNT TAB	42
DETAILS	43
FEATURE CODE	43
ACTIVATING A FEATURE CODE	43
Technical Specifications and Safety Notifications	45

Table of Contents

English	45
Dansk (Danish)	47
Deutsch (German)	49
Español (Spanish_Argentina)	51
Français (French)	53
Italiano (Italian)	55
Magyar (Hungarian)	57
Nederlands (Dutch)	59
Polski (Polish)	61

IMPORTANT INFORMATION

Refer to the hardware installation manual for complete installation requirements before operating the system.

TRADEMARK

All brands and products names, unless otherwise stated, are registered trademarks of Novariant, Inc. and Ag Leader® Technology

TECHNICAL SUPPORT

Contact your Ag Leader Dealer or Ag Leader Technology for technical support.

Telephone: (515) 735-7000

Email: support@agleader.com

LEGAL DISCLAIMER



NOTE!: Read and follow ALL instructions in this manual carefully before installing or operating the system.



NOTE!: Take careful note of Safety Information section of this manual and additional safety messages provided throughout this and any other supplemental manuals provided.

Manufacturer disclaims any liability for damage or injury that results from failure to follow instructions, cautions, and warnings set forth herein.

1. There is NO obstacle avoidance system included with manufacturer's product. A person must always be present in operator's seat when the system is in use to avoid obstacles such as people, animals, trees, ditches, buildings, etc. and to control vehicle to avoid them if necessary.
2. The system does NOT control speed of vehicle. Operator must always adjust speed of vehicle manually so that it is operated at a safe speed that will not cause vehicle to roll over or go out of control.
3. The system will take over control of vehicle's steering system when system is activated during testing, calibration, tuning, and automatic steering operations. Vehicle's steering axles, tracks, articulation point, or wheels may move unpredictably when activated. Prior to starting vehicle and/or activating system, verify that all people and obstacles are clear of vehicle to prevent death, injury, or damage to property.
4. Use of the system is NOT permitted while vehicle is on public roads or in public areas. Verify that system is powered OFF before driving on roads or in public areas.

SAFETY INFORMATION

WARNING ALERTS

System installer and manufacturer disclaim any responsibility for damage or physical harm caused by failure to adhere to following safety requirements:

- As operator of vehicle, you are responsible for its safe operation.
- System is not designed to replace vehicle's operator.



WARNING!: After installation of the system, verify that all screws, bolts, nuts, and cable connections are tight. Verify that all cables have been secured to prevent them from being damaged.



WARNING!: To understand potential hazards associated with operation of a autosteer equipped vehicle, read provided documentation prior to installing or operating system on a vehicle.



WARNING!: To prevent accidental death or injury from being run over by vehicle, never leave vehicle's operator seat with system engaged.



WARNING! To prevent accidental death or injury from being run over by vehicle verify that area around vehicle is clear of people and obstacles before startup, calibration, tuning, or use of system.



WARNING! To prevent accidental engagement of system and loss of vehicle control, shut down system while driving on roads. Never drive on roads or in public areas with system powered up.



WARNING! Verify that you are in a stable position on vehicle's platform or stairs when installing or removing antenna assembly on top of cab so you do not fall. If vehicle does not provide a safe platform, use a ladder to safely access vehicle's roof.



WARNING! To avoid electrical shock hazards, remove antennas from vehicle before driving under low structures or low electrical power lines.

CAUTION ALERTS

System installer and manufacturer disclaim any responsibility for damage or physical harm caused by failure to adhere to following safety requirements:



WARNING! System does not detect obstacles in vehicle's path. Vehicle operator must observe path being driven and take over steering manually if an obstacle must be avoided.



WARNING! System does not control speed of vehicle. Operator must manually adjust speed of vehicle to keep vehicle safely under control.



WARNING! System must be powered OFF when installing or removing the ECU-S1, or any other part of system.

INSTALLATION

OVERVIEW

1. Display Kit
2. GPS Smart Antenna Kit
3. System Kit (OnTrac3)
4. Vehicle Installation Kit
5. Accessory Kit

DISPLAY KITS

The system is compatible with multiple display options. Displays are ordered as a separate component and include their own installation and operator's instructions. Display Operator's Manual will show how display and display harnesses are installed on a vehicle and how they are connected to ECU-S1 harnesses.

ETHERNET TO DISPLAY—RJ-45 connector that is plugged into Ethernet port on display or display Harness to provide communications between display and ECU-S1.

POWER ACTIVATION—Connection to display or display harness that provides a signal that commands system to power up. When this signal is turned off, system will power down.

UNSWITCHED POWER—Power source that provides 12 volts of unswitched DC power to system. Power source should not be connected to a power supply that is connected to vehicle's ignition. This source should be shown or explained in Display Operator's Manual.

WiFi—ECU-S1 is equipped with a WiFi modem which will allow user to utilize a tablet or laptop with Wifi capabilities.

Display Kit will provide necessary harnesses and instructions to provide power to system and allow communications between display and steering controller. Use those instructions to complete display installation and to connect display to system after display mount has been installed.

GPS/GNSS SMART ANTENNA KIT

The ECU-S1 does not contain any GPS receiver or cell modem. It requires the addition of an external GPS receiver for GNSS data.

ECU-S1 KIT

i NOTE!: This system kit represents parts that are common in all installations.

- System kits include a Control Unit (ECU-S1), ECU-S1 Main Harness, and User's Manual
- Refer to your AutoSteer dealer for exact part numbers.

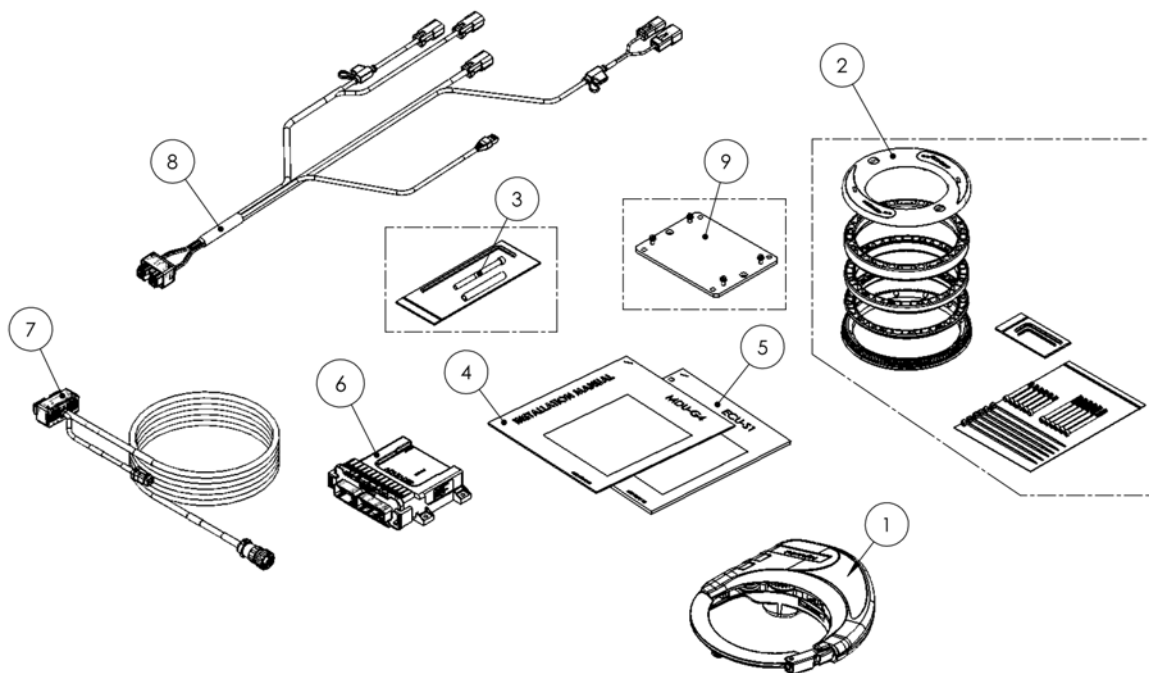

Item	Component	Part Number
1	MDU-G4	4100971
2	Steering Wheel (Switch) kit	126-0041-01
3	Anti-Rotation Pin, assembly	200-0752-01
4	Installation Guide MDU-G4	602-0546-01
5	Operator's Manual OnTrac3	602-0559-01
6	OnTrac3 Control Unit (ECU-S1)	4100970
7	MDU-G4 Harness	201-0603-01
8	OnTrac3 ECU-S1 Harness	201-0605-01
9	OnTrac3 ECU-S1 Bracket	200-0627-02

VEHICLE INSTALLATION KITS

System is designed to be compatible with many makes and models of vehicles available in today's agricultural market. The system is brand neutral and can be installed on any manufacturer's vehicle including AGCO, Ag Chem, Case, Challenger, Fendt, John Deere, New Holland, Massey Ferguson, and many others. The system is also capable of being installed on a variety of platforms including articulated tractors, combines, MFWD and standard front axle tractors, floaters, sprayers, swathers, track tractors, and others. Same user interface can be used on all vehicles, regardless of make or model, making it easy for drivers to become familiar with controls even if the system is installed on multiple vehicle types.

To make installations simple and reliable, many vehicle-specific installation kits have been designed to fit on each individual make and model. These kits are available for vehicles that come from factory with a factory installed steering system (ex. Steer Ready, CAN Bus, or ISO Ready) as well as options for those vehicles that need a complete steering kit installed. Even if there is not a vehicle-specific kit available for vehicle, properly trained installers can use a generic

installation kit to connect system to vehicle. Specific instructions for vehicle installation kits are provided with installation kits. Refer to those instructions when installing vehicle kit.

i NOTE!: List of supported vehicle-specific kits is always being expanded. Contact your Ag Leader dealer for latest list of vehicle-specific installation kits to see if vehicle being installed on has a released kit.

ACCESSORY KITS

Refer to installation manual for any Accessories available for Steering Controller

TRANSFERRING SYSTEM FROM VEHICLE TO VEHICLE

System is designed to be easily transferred from vehicle to vehicle. Specific vehicle kits are available that can be installed on each vehicle so that only display, GNSS Smart Antenna, and Control Unit needs to be transferred from vehicle to vehicle. Each vehicle that system is to be transferred to should have display harness, power harnesses, and vehicle harnesses already preinstalled. Contact your Ag Leader dealer for information about obtaining and installing additional vehicle specific kits. Use the vehicle kit instructions to transfer system from one vehicle to another.

i NOTE!: Refer to manual for customer supplied GPS receiver and antenna for instruction on moving them.

REMOVING SYSTEM FROM A VEHICLE

1. Use a 1/4 inch nut driver to remove Main Cable Harness connector from ECU-S1.
2. Use a 1/4 inch nut driver to remove MDU-G4 harness from ECU-S1.
3. Remove four 8-32 x 1/2 Hex Screws using a 1/4 inch nut driver. This releases ECU-S1 from vehicle mounting bracket so it can be moved to another vehicle.
4. Remove display from cab using instructions provided in Display Operator's Manual.

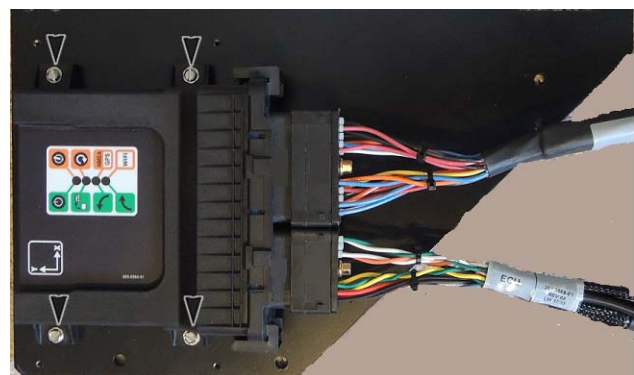
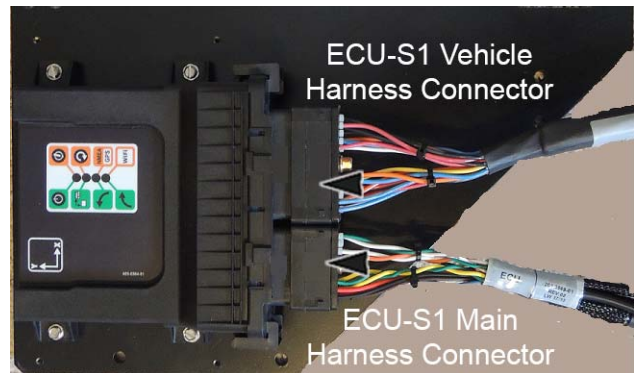

INSTALLING SYSTEM ON TO VEHICLE

1. Install display in cab using instructions provided in Display Operator’s Manual.
2. Attach ECU-S1 to mounting bracket with four 8-32 x 1/2 Hex Screws. Tighten screws using a 1/4 inch nut driver.

i NOTE!: Do not over tighten screws.

3. Attach Main Cable Harness connector to left side connector on ECU-S1. Match Yellow dots on harness to ECU-S1 Connector. Use a 1/4 inch nut driver to tighten connector.
4. Attach the MDU-G4 harness to right side connector on ECU-S1. Match White dots on harness to ECU-S1 Connector. Use a 1/4 inch nut driver to tighten connectors.

i NOTE!: Both connectors are keyed so they will only attach proper side of ECU-S1 and in one orientation. Connectors should slide easily onto receptacle. If they do not slide easily, try a different position. Do not force connector into receptacle as this could damage connectors.

5. Power up system and navigate to AutoSteer Setup screen. Use Manage Vehicles button to select and activate vehicle that system has been installed on. See [“MANAGE VEHICLE” on page 20](#) for information on setting active vehicle.

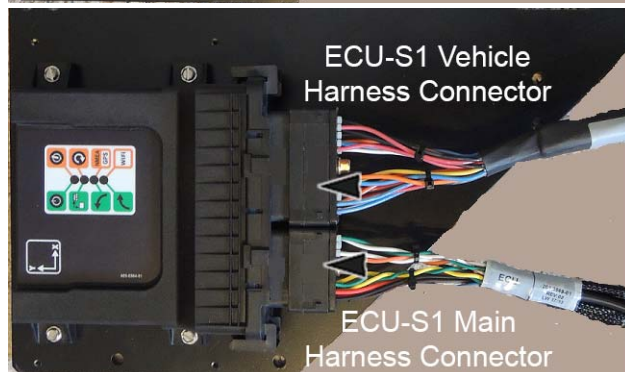
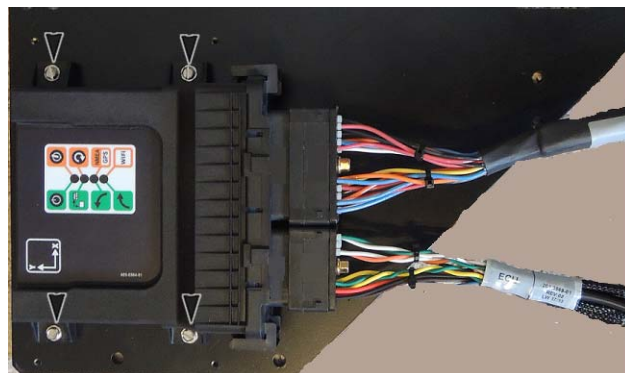

ECU-S1 LED DIAGNOSTICS

ECU-S1 has been designed with four LEDs that can be used to help determine status of system as well as provide some basic troubleshooting information. On front panel of ECU-S1, LEDs will be off, Green, or Amber.

Green Icons	Description	Amber Icons	Description
	Solid Green – Power No Color – No Power		Flashing Amber – Flashing Amber light indicates an issue with power or system boot error
	Flashing Green – Display Communication No Color – No Display Communication		Solid or Flashing Amber – Firmware Upgrade in Progress Do not power down until complete.
	Flashing Green – Left turn Command Signal No Color – No turn Command		Flashing Amber – GPS NMEA Communication
	Flashing Green – Right Turn Command Signal No Color – No turn Command		Flashing Amber – Wifi Communication A flashing Amber light indicates a WiFi communication has been established.

ACCESSING AUTOSTEER SETUP SCREENS

The system adds vehicle steering control to compliment features of the display. Settings, configuration options, and monitoring features for GPS and vehicle communications are kept separate from display controls. To access these system specific screens, navigate to AutoSteer Setup screens from display using the following button presses:

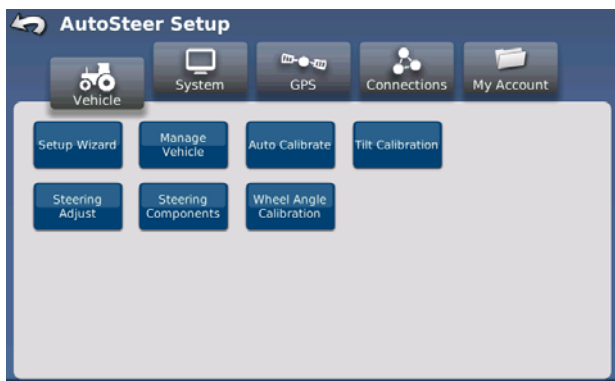
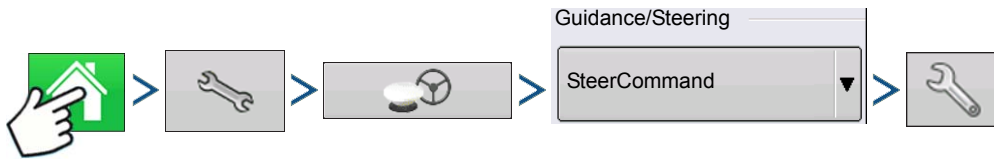

Folder tabs along top of screen separate configuration and monitoring functions into sub groups to simplify management.



VEHICLE—Setup Wizard, Manage Vehicles, Auto Calibrate, Tilt Calibration, Steering Adjust, Steering Components, Wheel Angle Calibration

For more information, see [“VEHICLE TAB” on page 7](#).



SYSTEM—System Health, Manage Settings, Accessories, Technician, Software Upgrade, System Log

For more information, see [“SYSTEM TAB” on page 27](#).

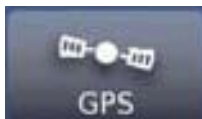

GPS—GPS Diagnostics, Precision Settings

For more information, see [“GPS TAB” on page 37](#).



CONNECTIONS—WiFi

For more information, see [“CONNECTIONS TAB” on page 41](#).



MY ACCOUNT—Details, Feature Code

For more information, see [“MY ACCOUNT TAB” on page 42](#).

VEHICLE TAB

Vehicle tab enables user to configure a new vehicle, manage existing vehicles, perform an auto calibration of a vehicle, make steering adjustments and manage steering components. This menu allows user to configure and monitor various components related to vehicle interface with ECU-S1.

To access Vehicle menu, refer to Display Operator’s Manual for instructions on accessing AutoSteer Setup screens. Vehicle menu will be first one that is displayed when AutoSteer Setup screen is accessed.

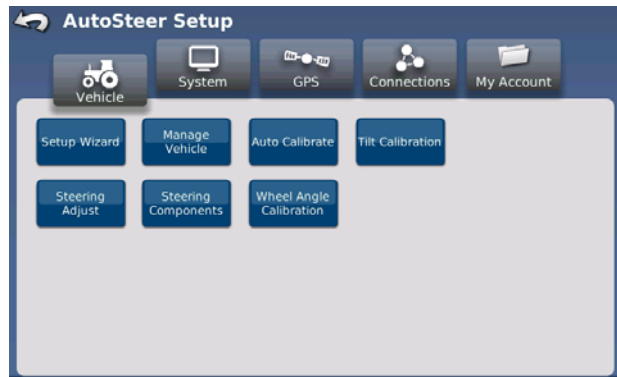

Setup Wizard—Walks user through setting up a new vehicle.

Manage Vehicle—Allows user to select, edit, delete, or import/export vehicle’s profile on system.

Auto Calibrate—Allows user to start or restart a vehicle calibration for current vehicle.

Tilt Calibration—Uses sensors to determine tilt of vehicle.

Steering Adjust—Allows user to make adjustments to steering response, line acquisition, heading aggressiveness, and reverse response.

Steering Components—Provides status screens and set some values for all components that are connected to vehicle. This includes steering kick out information, Remote Engage detection, etc.

Wheel Angle Calibration—Calibrates reading from Wheel Angle Sensor. Wheel Angle Sensor sends wheel angle position signals to system.

STANDARD SETUP WIZARD STEPS

Setup Wizard is a step-by-step guide that leads user through procedure required to create a new vehicle profile. Setup Wizard procedure will change depending on what type of vehicle is selected and/or what options are installed on system. Not all screens described in this manual will be displayed for all vehicle setups.

To setup a new vehicle profile, press:



Select Vehicle Type

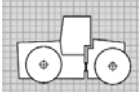

Articulated—Large four wheel drive vehicles that steer by articulating center of vehicle, includes Quadtrac.

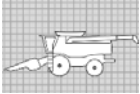

Combine—Grain harvesting and forage harvesting machines where rear axle is used to steer vehicle.

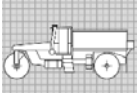

Floater—Three and four wheeled vehicles with large flotation tires used to spread fertilizer or chemicals on broad acres at high speeds.

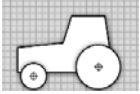

MFWD—Standard tractors with steering axle on front of machine.

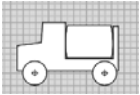

Sprayer—High clearance self propelled sprayers with spray booms.

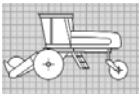

Swather—Swathers and self propelled mowers.

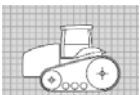

Track—Vehicles with tracks.

Press  to continue to next step.

Select Vehicle Make

Vehicle Make represents the manufacturer of the vehicle. Vehicle manufacturers that have Vehicle Specific Kits are shown in the list. Select desired vehicle by highlighting blue (make).

Press  to continue to next step.



NOTE! If vehicle manufacturer is not listed on this screen, select Generic from list. This allows you to create a vehicle that does not have a factory supported installation kit.

Select Vehicle Model

Vehicle Model represents the model of vehicle. If model has a Vehicle Specific Kit it will be shown in the list. Select desired vehicle by highlighting blue (model).

Press  to continue to next step.



NOTE! If vehicle model is not listed on this screen, select a model that is similar to one that is being installed on or go back to Vehicle Make screen and select Generic from list. This allows you to create a vehicle and model that does not have a factory supported installation kit.

Select Controller Type

Controller Type represents controller ECU-S1 will be interfaced with in order to steer vehicle.

MDU-G4 – MDU-G4 (Mechanical Drive Unit)

Select desired controller by highlighting blue.

Press  to continue to next step

Name Vehicle

 NOTE!: Vehicle Name screen allows user to enter a custom name for vehicle. This name is independent of name provided on display side of vehicle setup. You cannot use a name twice in the system. Type the desired vehicle name and enter.

Press  to continue to next step

Wheel Base

This measurement is only required for vehicles with two axles. The distance between front and rear axle is the vehicle's Wheel Base. Measure distance and enter value.

 NOTE!: Always measure both sides of vehicle and use average of two measurements.

 NOTE!: Units of measure shown in AutoSteer Setup pages are configured on display side and passed to ECU-S1 menus. Refer to your Display Operator's Manual for instructions on how to set units of measure.

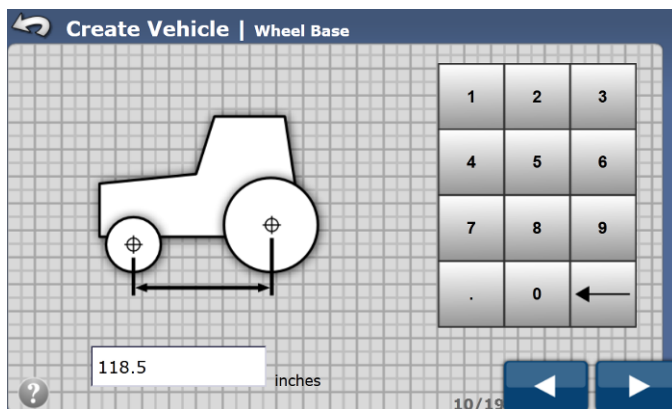

 NOTE!: Be sure to verify that measurement entered is in same units that display is expecting. Expected unit of measurement is shown to right of data input box.

 NOTE!: This measurement should be accurate to within 2 inch (5.0 cm).

Press  to continue to next step

Antenna Fore/Aft

Antenna Fore/Aft—Distance between GPS antenna and pivot point.

Pivot Point is where vehicle rotates as it turns. Pivot Point depends on steering method. Common Pivot Points are:

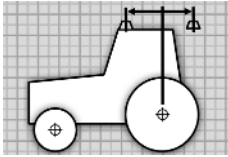

Front Axle Steering—Rear axle for MFWD, SPRAYER, and FLOATER vehicles.

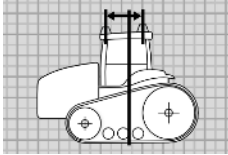

Track Vehicle—Center point of track.

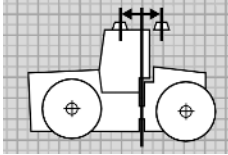

Articulated Vehicles—Articulation joint of vehicle.

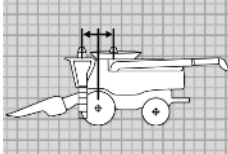

Rear Axle Steering—Front axle for COMBINE and SWATHER vehicles.

First identify Pivot Point on vehicle that system is being installed on. Measure distance between Pivot Point and GPS antenna and enter value.

Fore—Antenna is located in front of Pivot Point.

Aft—Antenna is located behind Pivot Point.

After Antenna Fore/Aft has been entered, press  to continue to next step.

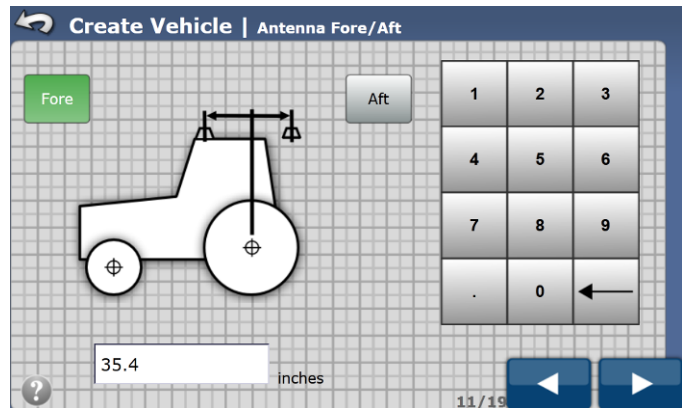

 NOTE!: GPS antenna can be mounted in front or behind Pivot Point. Press button that indicates which side of Pivot Point GPS antenna is mounted. If value is 0.0, it does not matter which button is pressed.

Antenna Lateral Offset

Antenna Lateral Offset is distance between center of drawbar and GPS antenna. This value is 0.0 if antenna is mounted in center of vehicle. If antenna is not mounted in center, measure offset and enter value. Value will be adjusted after calibration process to ensure center of vehicle is in same position going both directions on A/B Line.

 NOTE!: If Antenna Lateral Offset is ever changed by more than 4.0 inches (10.2 cm), a new calibration procedure must be performed on vehicle.

For best results, GPS antenna should be mounted along centerline of vehicle; however it can be mounted to left or right of centerline if necessary. The direction of offset is highlighted green. Press button that indicates which side of centerline GPS antenna is mounted. If offset is 0.0, it does not matter which one is selected.

Left—GPS is left of centerline.

Right—GPS is right of centerline.

Press  to continue to next step.

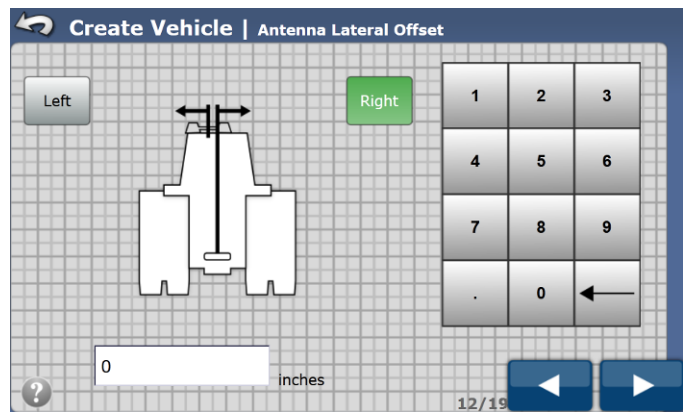

Antenna Height

Antenna Height—Distance from ground to GPS antenna.

Measure distance from ground to GPS antenna. Enter value into Antenna Height window.

Press  to continue to next step.

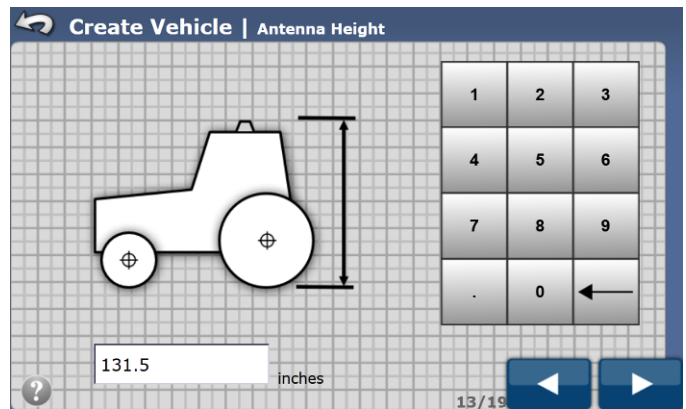

ECU-S1 Fore/Aft

Like the GPS antenna, the location of ECU-S1 must be entered into the system. All measurements entered into the system should be measured to the center of the ECU-S1 on the top surface.

ECU-S1 Fore/Aft—Distance between ECU-S1 and Pivot Point.

Pivot Point of vehicle is the same point used to enter Antenna Fore/Aft. For an explanation of Pivot Point on vehicle, see [“Antenna Fore/Aft” on page 9](#). Identify Pivot Point on vehicle and then measure distance between Pivot Point and center point of the ECU-S1. Enter value into system Fore/Aft window.

 **NOTE!** The red dot is not printed on the ECU-S1. It is shown here only to approximate the measurement point on the ECU-S1.

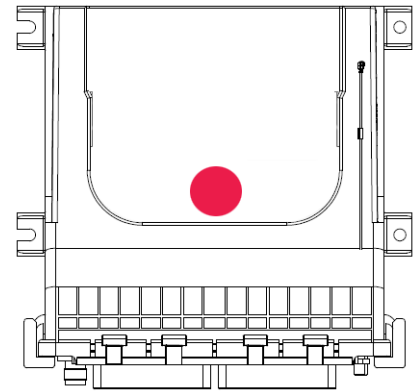

Fore—ECU-S1 is located in front of Pivot Point.

Aft—ECU-S1 is located behind Pivot Point.

Selected button turns green.

Press  to continue to next step.

NOTE!: ECU-S1 can be mounted in front or behind Pivot Point. Press button that indicates which side of Pivot Point ECU-S1 is mounted. If value is 0.0, it does not matter which button is pressed.

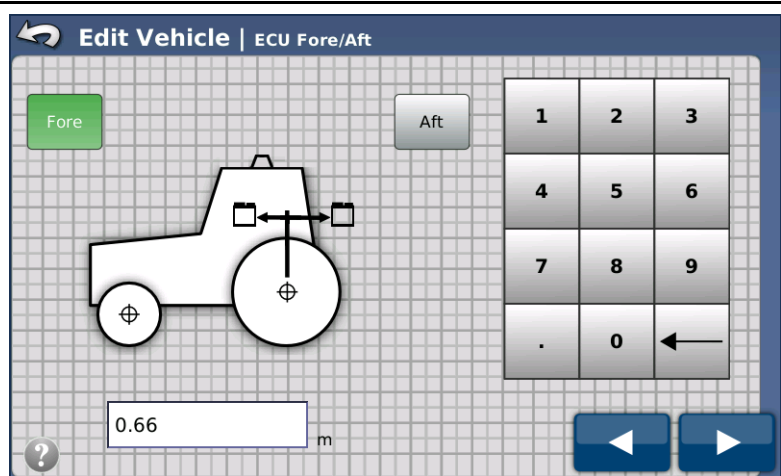

ECU-S1 Lateral Offset

ECU-S1 Lateral Offset is the distance from center of drawbar to center point of ECU-S1. Unlike Antenna Lateral Offset, value should not be adjusted once entered, unless, it's later determined to be incorrect. Measure between center of vehicle (typically the draw bar) and ECU-S1 and enter value.

The ECU-S1 can be mounted to the left or right side of centerline. Press button that indicates which side of centerline ECU-S1 is mounted. If offset is 0.0, it does not matter which one is selected. Selected button turns green.

Left—ECU-S1 is left of centerline.

Right—ECU-S1 is right of centerline.

Press  to continue to next step.

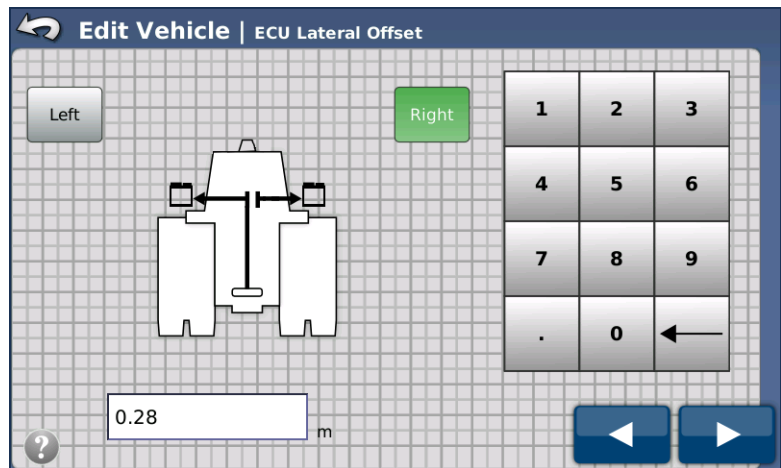

ECU-S1 Height

ECU-S1 Height - Distance from ground to center of ECU-S1.

Measure distance from ground to ECU-S1 and enter value.

After ECU-S1 Height has been entered, press  to return to any of previous steps to modify a previously entered value. Press

 to continue to next step.

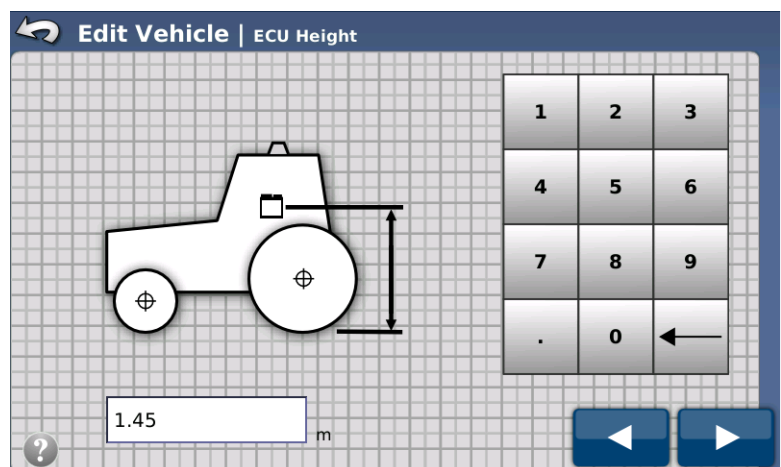

ECU-S1 Orientation

The system needs to know how the ECU-S1 is oriented or the system will not work properly. If the ECU-S1 has been installed according to Vehicle Specific Installation Instructions, orientation will already be shown on Orientation screen.

A graphic showing how the ECU-S1 is installed compared to the vehicle is shown on left. The view will always be as if user is looking down from the top of cab with front of vehicle pointing to top of screen.

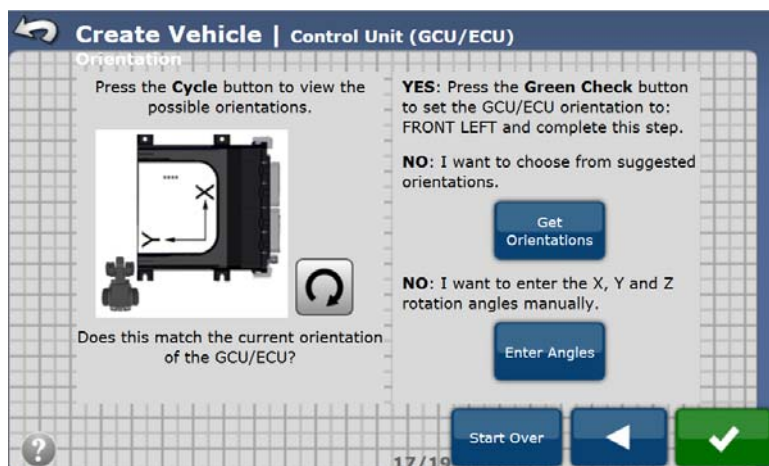

i NOTE!: A small tractor icon showing a tractor from above will be shown in all graphics to help user visualize how ECU-S1 should be installed on vehicle.

If default position shown matches actual mounting position of installation, press  to continue to next step.

If default orientation does not match your installation, there are two options:

Get Orientations—Use this button if ECU-S1 orientation is not shown in diagram and ECU-S1 is at a 90° angle or some multiple of 90° (0°, 90°, 180°, 270°) at all three axes (vertically, horizontally, and perpendicular to other two) when compared to direction of travel of vehicle.

Enter Angles—Use this button if ECU-S1 orientation is not shown and it is not mounted at a 90° angle to direction of travel. This is only used when custom angles must be entered. Contact your AutoSteer Dealer for assistance in entering correct angles.



Get Orientations

When Get Orientations button is pressed, it is expecting that the ECU-S1 is installed in one of 24 possible orientations. To simplify selection, system will use built in sensors to detect which way gravity is pulling on the ECU-S1. This allows the system to narrow choice of orientations down to four.

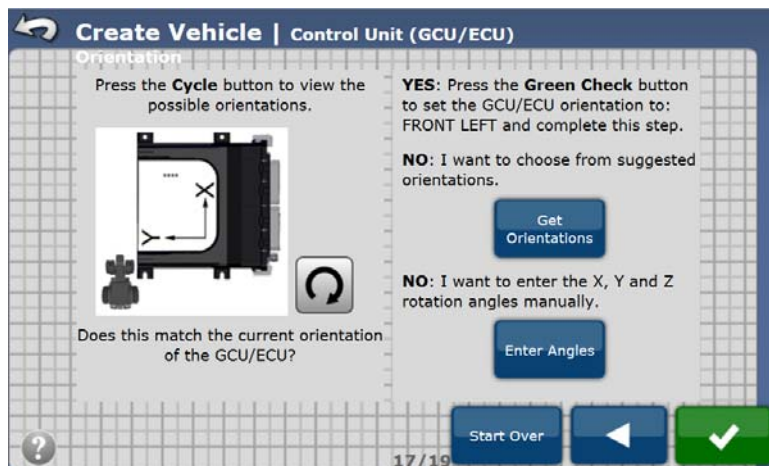
940





i NOTE!: If the ECU-S1 is not mounted orthogonally and this choice is used, system will not be able to properly show correct orientation. If an orientation is selected that is not exactly the way it is mounted on the vehicle, steering performance will be poor or not possible.

 **Cycle View**—This button cycles through four possible orientations that are detected by ECU-S1. Press this button until the figure on left side of screen shows ECU-S1 in same orientation as it is installed. When correct orientation is found, press  to save orientation and to continue to next step.

Start Over—If none of the orientations match, press the Start Over button to return settings back to default position. This will return back to beginning of ECU-S1 Orientation selection.

Enter Angles

When Enter Angles button is pressed, system will show a warning screen about how important it is to enter values accurately.

Press  only if angles have been provided by your AutoSteer Dealership. If angles are not known, press .

 **NOTE!** Only properly trained technicians should use this option. Angles need to be precisely measured and calculated to allow system to work properly. Entering incorrect values will cause system to perform poorly. Always attempt to mount the ECU-S1 at 90° angles if possible. Always contact your AutoSteer Dealer for assistance when entering correct angles.

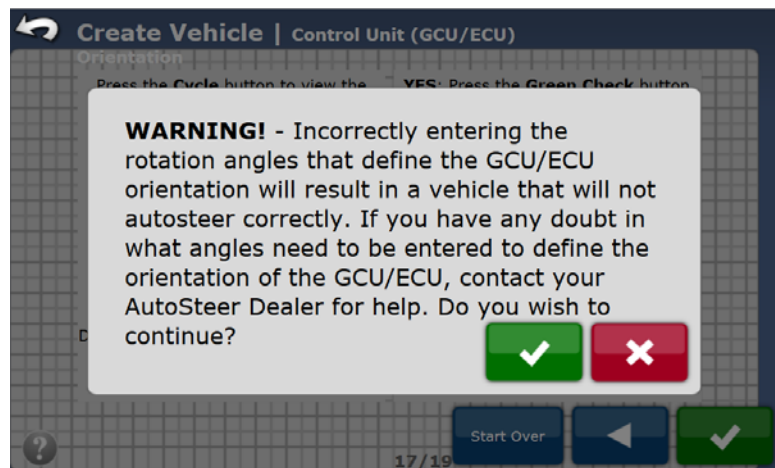

Once Warning screen has been accepted, system expects user to enter custom angles to tell system how ECU-S1 is mounted. These angles must be accurate. There are three angles that need to be entered.

(X) Pitch—Front to back rotation of ECU-S1 as compared to vehicle.

(Y) Roll—Side to side rotation of ECU-S1 as compared to vehicle.

(Z) Yaw—Rotation of ECU-S1 compared to vehicle looking down from top.

To determine angles to enter, start with a ECU-S1 with a rotational settings of (X=0, Y=0, Z=0). This orientation is with ECU-S1 upside down with connectors pointing to left side of vehicle. This is the Base Orientation Position which all rotations need to be measured from.

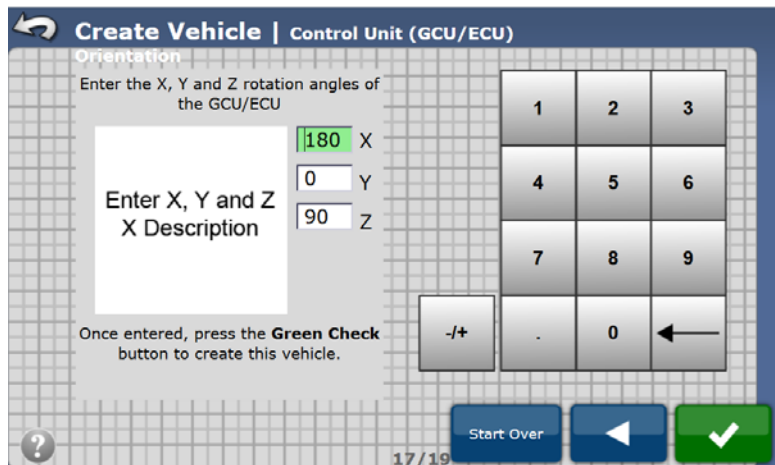

 **NOTE!** Figure shows ECU-S1 upside down with connectors pointing to left side of vehicle. This is the Base Orientation that all angle measurements are measured from. X and Y arrows are not printed on this side of ECU-S1 and are shown only as a reference.

Adjust angles for X, Y, and Z so that they tell the system how many degrees it must be rotated from Base Orientation Position to match actual orientation on vehicle. This process should only be performed by someone that has had proper training. Contact your AutoSteer dealer for support.

Besides entering angles, you have one other option:

Start Over—Press this button to return settings back to default position of vehicle profile selected. This will return the screen back.

Press  to save orientation and to continue to next step.

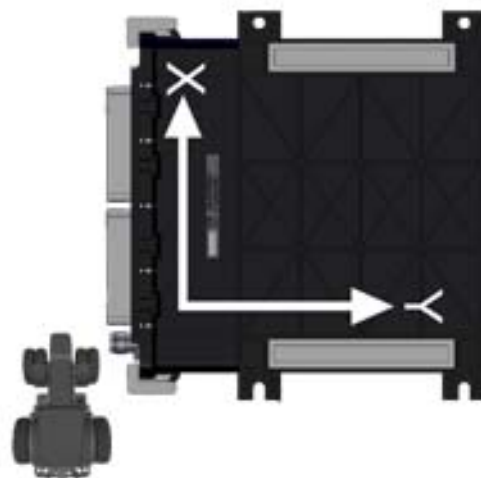

Manual Steering Override

Manual Steering Override refers to sensor that is used to detect when operator manually turns steering wheel. The system uses this to know when to stop steering. Manual Steering Override screen shows status of that sensor and allows user to adjust the sensitivity of sensor. Exact screens depend on vehicle profile detected.

 **NOTE!** It is critically important for Manual Steering Override to be functioning and set to proper level to allow user to disengage AutoSteer manually. Never operate an AutoSteer system without this feature working or set properly.

Kickout

Screenshot and interface description needed.

Information and controls available on Manual Steering Override screen for pressure transducers:

Steering Override Graph—Populates as shaded green area starting from left side of graph, kick out sensitivity setting is shown by triangles on bottom and top.

Saved—Value that is currently saved for manual kickout.

Current—Pressure reading determined by pressure transducer.

Minus (-) and Plus (+) Buttons—Increases or decreases setting for kick out pressure. This moves two triangles left or right on graph to manually adjust kick out pressure value.

Save Limit—If kick out pressure values are changed from saved values, press this button to save them. If they are not saved, any changes will be lost when user leaves this screen.

Start—Places system into an AutoSteer simulation. This will change to a Stop button after calibration start. Test kick out setting by turning steering wheel. If system reaches kick out setting, the stop button will change back to a start button. Use this procedure to test system and ensure kick out works properly.

Manual Steering Override Auto Calibrate

MDU-G4 Auto Calibrate

Manual steering override when using the MDU-G4 as the actuator is different than using a hydraulic pressure transducer or override switch. The ECU-S1 detects manual steering override using feedback from the MDU-G4. In this screen the bar graph represents the current tested setting and pressing the - or + will adjust this bar graph.

After adjusting the manual override setting pressing the start button will turn the steering wheel to the right and the setting can be tested. Once the setting is correct, pressing the Save Limit button will set the saved limit to match the tested limit.



AUTO CALIBRATE

Auto Calibrate wizard guides user through calibration process for the active vehicle. Calibration steps teach the system characteristics of the vehicle and the steps are critical to achieve optimal control performance. The Auto Calibration process can be paused and resumed at any point during the process.

i NOTE!: Auto Calibrate wizard takes a significant amount of space for your vehicle to operate within. Depending upon vehicle size, it may take up to 4.0 acres [approximately 300 x 600 ft] (1.6 ha [approximately 90 x 180 meters]) to complete Auto Calibrate procedure.

i NOTE!: Vehicle will execute a series of maneuvers during calibration process including turning full left and full right

Auto Calibrate wizard provides specific instructions about required area, speed, and engine RPM during each step of the process. Calibration steps and time vary according to vehicle type and equipment installed. Follow onscreen instructions to perform Auto Calibration procedure.

Calibration process can be broken into two areas:

OnTrac3 Specific Calibration Steps—Once Common Calibration Steps have been completed, Auto Calibrate wizard will go on to different steps depending on which vehicle type has been selected.

To start Auto Calibrate wizard, press Auto Calibrate button from AutoSteer Setup screen. Initial Auto Calibrate screen is displayed. This screen will be different depending on which vehicle type is being calibrated. Screen will summarize all steps required to complete calibration and provide an approximate amount of time each step will take.

i NOTE!: All of steps of routine must be completed and changes saved before system is allowed to AutoSteer vehicle.

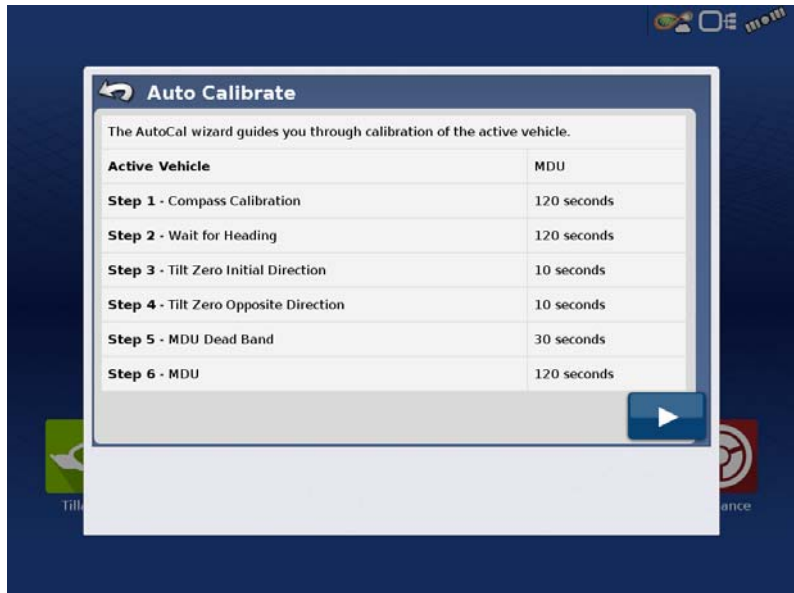

COMMON CALIBRATION STEPS

i NOTE!: All three Auto Calibrate wizard processes will start with same Common Calibration Steps. They are as follows:

Compass Calibration—Calibrates ECU-S1 electronic compass.

Wait For Heading—Step to verify that compass and heading calculation are equal.

Tilt Zero Initial Direction—Initial step for calibrating terrain compensation sensors.

Tilt Zero Opposite Direction—Second step for calibrating terrain compensation sensors.

MDU Deadband/MDU—Calibrate mechanical drive unit.

i NOTE!: Auto Calibrate procedure requires a significant amount of space. Find an adequate location before starting Auto Calibration process.

To start Auto Calibrate process, press  in Auto Calibrate screen.

Compass Calibration

The ECU-S1 has a built in compass that allows it to determine vehicle direction. To calibrate the compass, drive vehicle in a circle at a constant speed, to allow system to compare compass readings with GPS information.

To successfully calibrate compass, start driving vehicle 1/2-2 mph (0.8-3.2 k/h). Turn steering wheel and hold it at a constant angle so vehicle will make a constant radius circle. Steer vehicle so it makes a circle around 30-50 ft (9.1-15.2 m) in diameter.

When vehicle is moving at correct speed and in a circle, press  to start calibration. Continue driving in a circle until compass calibrates and the Waiting for Heading screen appears.

i NOTE!: In order to increase integrity of Compass Calibration, driver must hold steering wheel at a constant angle and keep vehicle at a constant speed. Do not start calibration process until vehicle is in this constant arc.

i NOTE!: Pressing Pause button and then pressing Resume button will restart Compass Calibration from beginning. Do not press Pause button unless vehicle is going to cause an accident.

When Compass Calibration steps have completed, system will automatically move on to next step.

Wait For Heading

After compass has been calibrated, system will display a verification screen. This screen shows a compass with a red needle and a green shaded area. Red needle represents calculated heading based on GPS. Green shaded area represents measured compass heading. If calibration was successful, the red needle and shaded green area should be pointing the same direction.

1. Start driving in a straight line at 5 mph (8 k/h). Observe red needle and green shaded area. Both should line up within a few seconds.
2. When vehicle has reached minimum speed, verification process will begin and display will show system is WARMING UP. Continue driving in a straight line.

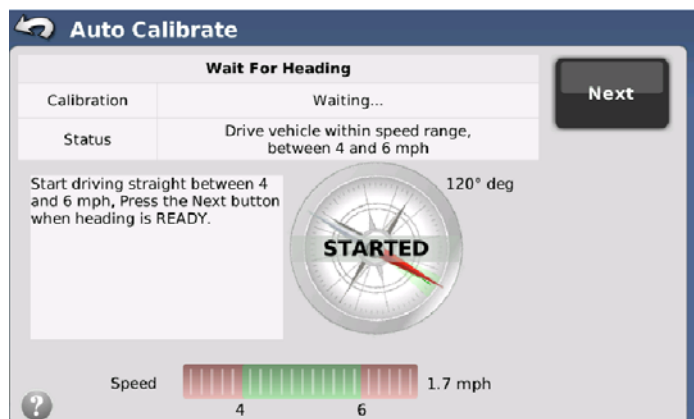

Compass Verification Warming Up

3. If calibration was successful and there are no problems, system should quickly show arrow and shaded area aligned and pointing in direction vehicle is traveling.
4. At this point, press Green Next button to continue with the next step of the calibration.
5. Compass Calibration Successful

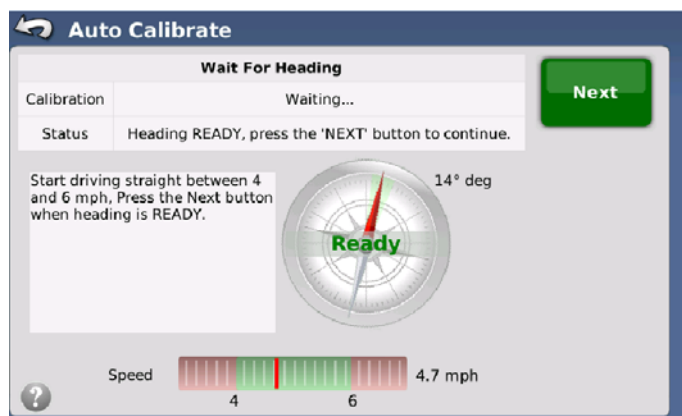

i NOTE!: If red needle and green shaded area do not line up within a minute after WARMING UP stage begins, Navigate to Edit Vehicle screens and verify that the ECU-S1 has been set to correct orientation. If orientation has been set incorrectly, system will not be able to accurately determine a heading. Drive vehicle forward for 500 feet (152 meters) and then restart calibration.

Tilt Zero

The system measures the tilt of the vehicle to calculate vehicle position.

1. Park vehicle on a flat area and allow system to take sensor readings to get a base line.
2. Turn vehicle to face the opposite direction at the exact same spot. System then takes sensor readings while in that direction.

System is now able to precisely measure vehicle tilt.

Initial Direction

i NOTE!: It is important that Tilt Calibration takes place on a flat area. If this step is performed on a slope, system may not be able to accurately control vehicle.

To start Tilt Zero Initial Direction calibration, drive vehicle onto a flat surface and put in park or set park brake. Press Resume button and wait for system to finish this step. When this step is complete, calibration process will automatically move on to next step.

Opposite Direction

This is second stage of this calibration procedure.

i NOTE!: It is important that vehicle is positioned in exact same place as previous step but facing in opposite direction. If vehicle is not placed in same position, tilt compensation will be incorrectly calculated and vehicle steering performance will be degraded.

To finish Tilt Calibration, turn vehicle around and park in exact same location so that rear tires are now over marks of front tires (center of track is at same point but in opposite direction). Press the Resume button and wait for system to finish measuring.

System will then automatically jump to the next step. This is the end of Common Calibration Steps.

Mechanical Steering Unit (MDU-G4)

Perform a series of left and right turns at differing turning rates to calibrate the MDU-G4.

MDU-G4 Deadband —This step determines minimum current required to start turning steering wheel to the right and to the left.

i NOTE!: Verify that engine RPM is at working speed while this part of calibration is taking place.

First part of test measures minimum current required to start turning steering wheel to right and to left. To begin calibration, start driving vehicle in a straight line between 2.0 and 5.0 mph (3.2 and 8.0 k/h). Press Resume button to begin calibration process.

Calibration process will perform a series of left and right turns at various rates of speed.

The calibration system determines the minimum amount of effort required to turn wheel in either direction and calibrates the rate of turn for specific steering wheel positions.

Once MDU-G4 Deadband calibration process has completed, Save Calibration screen will appear.

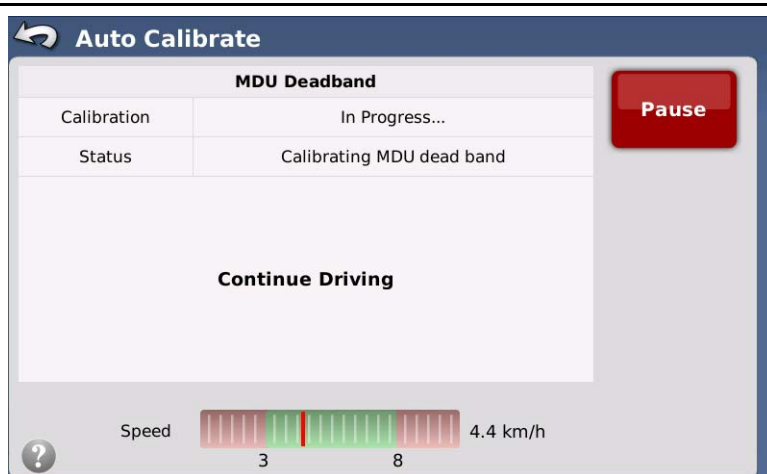

Press  to accept and save calibration. Press  to discard all changes, and start calibration from the beginning.

ADJUST ANTENNA LATERAL OFFSET

After vehicle has been created and calibrated, perform following procedure to ensure that lateral offset is entered correctly. This procedure will detect and eliminate skips and overlaps in adjacent rows due to an incorrect lateral offset.

 NOTE!: Before calibration process was started, Antenna Lateral Offset value should be as close to 0 as possible. If value is off by more than 4.0 inches (10.2 cm), calibration process will have to be redone after changing this value.

 NOTE!: Always verify that implement selected on the display during this test on display has a zero offset even if there is no implement on back of vehicle. Any vehicle offsets will cause an incorrect measurement to be entered in this procedure.

Set an AB line, engage AutoSteering, and let vehicle AutoSteer for at least 100.0 feet (30.5 m).

Stop vehicle, place it in park, and disengage system.

Use a plumb bob to place a flag in ground directly beneath center of draw bar.

Return to vehicle, start system, and engage AutoSteer for at least another 100.0 feet (30.5 m) on same AB line.

Disengage AutoSteer, turn vehicle around, and Auto Steer back down same AB line in the opposite direction.

When vehicle's draw bar reaches the flag, stop vehicle, place it in park, disengage autosteer system, and exit vehicle.

Check to see if center of draw bar is over flag.

If flag is exactly beneath center of draw bar, no adjustment is needed.

If not, use a plumb bob to mark a spot directly beneath the draw bar, and then measure the distance between that spot and the previously placed flag.

Calculate Offset Error by dividing measured distance by 2. (measurement is divided by two because taking measurements driving in opposite directions doubles any error.)

From AutoSteer Setup Vehicle screen, go to Manage Vehicle > Edit >Antenna Lateral Offset screen. Adjust existing value by adding or subtracting Offset Error.

 NOTE!: This measurement may require that Left or Right button may have to be changed.

Repeat procedure to ensure that lateral offset is now correct using a new A/B line for both directions.

i NOTE!: Always make sure draw bar is centered on vehicle and measure from this point for this test. This is point where implement will be attached and thus be expected to repeat in same point in both directions. If wheels of vehicle are equally spaced from draw bar, they should pass over top of each other in opposite directions in this test. However this measurement must be confirmed prior to using wheel tracks for offset measurements. Measuring from draw bar will always provide most consistent results.

Example:

After AutoSteering up and down AB line, if it is found that the center of draw bar is 3.0 inches (7.6 cm) to the right of the flag. Divide measurement by 2 for the number of passes, which gives an adjustment of 1.5 inches (3.8 cm). Go to Edit Antenna Lateral Offset screen and adjust lateral offset 1.5 inches (3.8 cm) inches to right (adjustment must be made in same direction of error).

i NOTE!: If adjustment is more than 4.0 inches (5.2 cm), vehicle will have to be recalibrated.

i NOTE!: Once Vehicle Antenna Offset has been determined, this value should NEVER need to be changed again unless GPS antenna has been physically repositioned on roof of vehicle. If a field operation shows a guess row error with a certain implement, offset should be adjusted on implement settings, NOT vehicle offset. Changing Vehicle Offset will cause other implements to show unpredictable guess row errors.

MANAGE VEHICLE

Manage Vehicles screen allows user to manage various vehicle profiles that may be loaded on system. System is designed to be easily moved from one vehicle to another. Each vehicle that it is installed on requires a new vehicle profile that saves settings, calibration, and tuning values specific to that vehicle. When system is installed on a different vehicle, user must use Manage Vehicle screens to activate proper vehicle profile.

Shows profile name, vehicle type, controller, and calibration status.

✗ Not Calibrated

✓ Calibrated

To access Manage Vehicles menu, press Manage Vehicles button from AutoSteer Setup screen. Manage Vehicles menu is displayed.

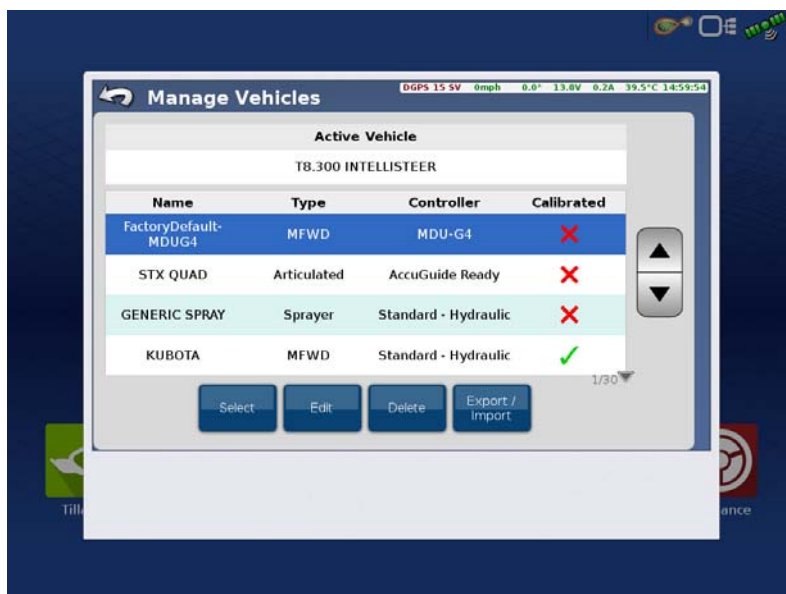

Manage Vehicles screen allows user to do four options. They are:

Select— This activates highlighted vehicle profile.

Edit—This allows user to modify measurements and ECU-S1 orientations that were entered during Setup Wizard process.

Delete—This allows user to delete a vehicle profile that is no longer needed.

Export/Import—This allows user to import or export vehicle profiles to or from other systems.

SELECT

Vehicle profile that is active on system is displayed in Active Vehicle box near top of screen. Active Vehicle must match vehicle that system is installed on for system to control it. A list of vehicle profiles stored on the system is displayed below Active Vehicle. If system is moved to a different vehicle, user must activate new vehicle in management screen.

To select a new vehicle, use Up/Down Arrows, or directly select vehicle from list, and highlight it. Press Select button to make highlighted vehicle active. This will change vehicle that is displayed in Active Vehicle box to one that was highlighted and reprogram ECU-S1 to control that vehicle.

After Select button has been pressed, a message is displayed telling user a new vehicle is now active.

Press  to continue and return to previous menu.

 NOTE!: Vehicle profiles used to control vehicles are stored on ECU-S1. These profiles are independent of vehicle configurations loaded in the display. Vehicle profile must be changed both on display as well as the system in order for it to properly interface with vehicle.

 NOTE!: For best performance, it is best to power cycle system after selecting a new vehicle profile.

EDIT

Edit button allows user to make changes to highlighted vehicle's configuration settings. These settings are same as ones entered during initial Setup Wizard procedure. Edit Vehicle screens will be labeled Edit Vehicle as shown.

To edit a vehicle, first use Up/Down Arrows or directly select vehicle from list and highlight it. Next, press Edit button. This will take the user through Edit Vehicle wizard. User can edit:

- Wheel Base
- Antenna Fore/Aft
- Antenna Lateral Offset
- Antenna Height
- ECU-S1 Fore/Aft
- ECU-S1 Lateral Offset
- ECU-S1 Height
- ECU-S1 Orientation

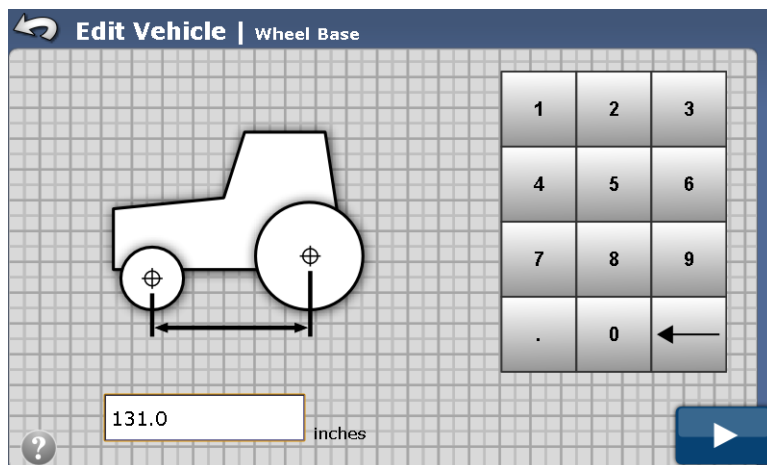

Edit Vehicle wizard will take user through above configuration options one at a time from top to bottom. Press  to move to next configuration screen. To escape Edit menu without saving any changes, press Previous Menu Arrow on top left corner of screen.

When all editable options have been cycled through Save Changes dialog box appears

Press  to save changes and return to Manage Vehicle screen. Press  to return back to Edit Vehicle screens.

 NOTE! User must cycle through all configuration screens and press in order to save any of the changes made. If user does not do this, changes will not be saved.

DELETE

Delete button allows user to delete highlighted vehicle profile from system.

To delete a vehicle, first use Up/Down Arrows or directly select vehicle from list and highlight it. Next press Delete button. Confirm Delete Vehicle message will appear.



NOTE!: Active Vehicle cannot be deleted. Select or create another vehicle and make it active, to delete previously active vehicle profile.

Press



to delete vehicle and return to Manage Vehicle screen. Press



to cancel deleting vehicle and return to Manage Vehicle screen.

EXPORT/IMPORT

Export/Import button allows user to import or export vehicle profiles to or from a USB drive to or from other ECU-S1 systems. Users may have more than one ECU-S1 system and multiple vehicles they work on. ECU-S1 system can also be transferred to multiple vehicles. Export/Import feature allows user to easily transfer all vehicle profiles to all ECU-S1 units in fleet.

Importing and exporting vehicles have following limitations:

- ECU-S1 you export from and ECU-S1 you import into must be running same firmware version.
- Only one vehicle can be imported and exported at a time from Manage Vehicle screen.

If there are multiple vehicles with same name on different ECU-S1s, copying vehicle profiles from one ECU-S1s to next may overwrite data. Each vehicle must have a unique name so data is kept separate when copying vehicles from one system to another.

For example if a customer has three JD8430 vehicles, each JD8430 must have a different name such as JD8430 1, JD8430 2, and JD8430 3. This limitation needs to be considered prior to creating a vehicle as name of vehicle in ECU-S1 cannot be changed after it has been created. To rename vehicle, user must create a new vehicle with desired name and recalibrate it.

To import or export a vehicle profile, press Export/Import button. This opens Export/Import Management screen.

Export/Import Management window gives user following options:



—Returns user to Manage Vehicles

screen.

Export to Display USB—Start process of exporting selected vehicle profile to USB on display.

Import from Display USB—Start process of importing a vehicle profile from USB drive on display.

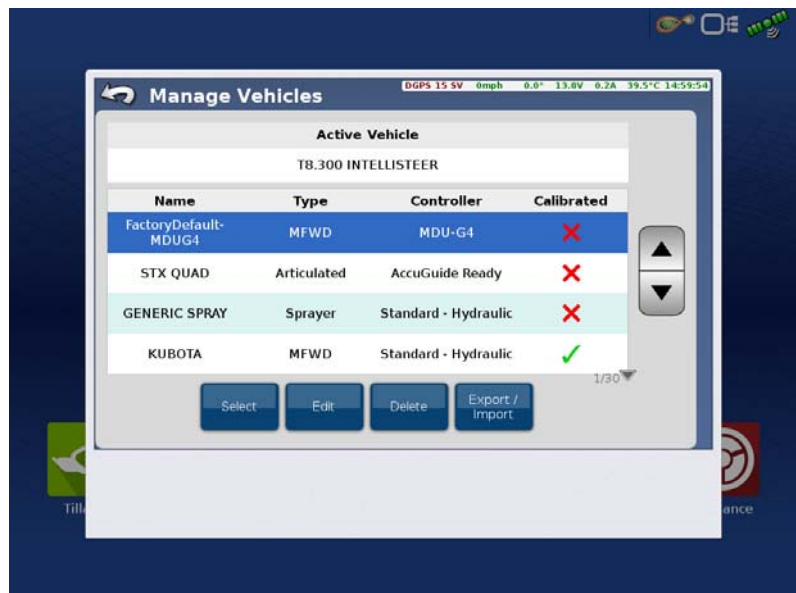

EXPORT TO DISPLAY USB

i NOTE!: When using WiFi or Ethernet connection to a Tablet or Laptop, Tablet or Laptop is considered display.

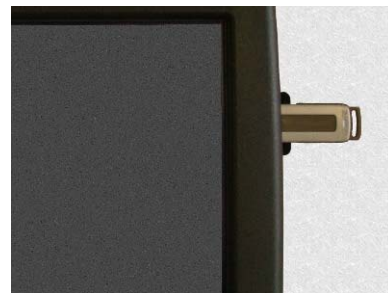

1. Insert a USB drive into display USB port.
2. Select vehicle profile that is to be exported by using Up/Down Arrows or by directly selecting vehicle from list by highlighting it.
3. Press Export to Display USB button.

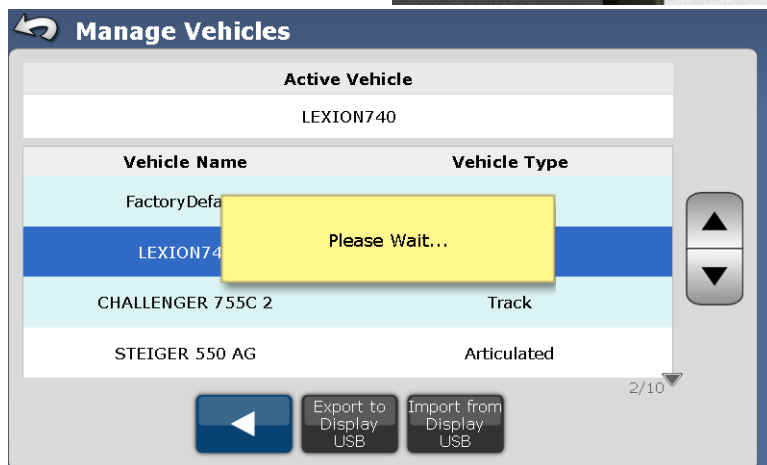

4. System will show a "Please Wait" message while it compiles information required to create export file.
5. Once file is ready for export, Export Vehicle to display screen will appear. Press Export button to export file.
6. Export process will begin. Screen will count down time until complete.
7. Once export is complete, press  to return to Export Vehicle to display screen.
8. Select the Previous Menu Arrow in top left corner of screen to return to Manage Vehicle menu. Export is now complete.



IMPORT FROM DISPLAY USB

1. Insert a USB drive with vehicle profiles to be imported using the display USB port.
2. Select Import from Display USB button.
3. Select file screen will be displayed. Press Choose File button to select file to be imported.
4. Stored files on USB drive will populate. Select vehicle file to import from list and then press  to start import.
5. Press Import button, which is now blue.
6. Wait for import to complete.
7. Import procedure is complete.
8. Press  to return to Manage Vehicles screen.

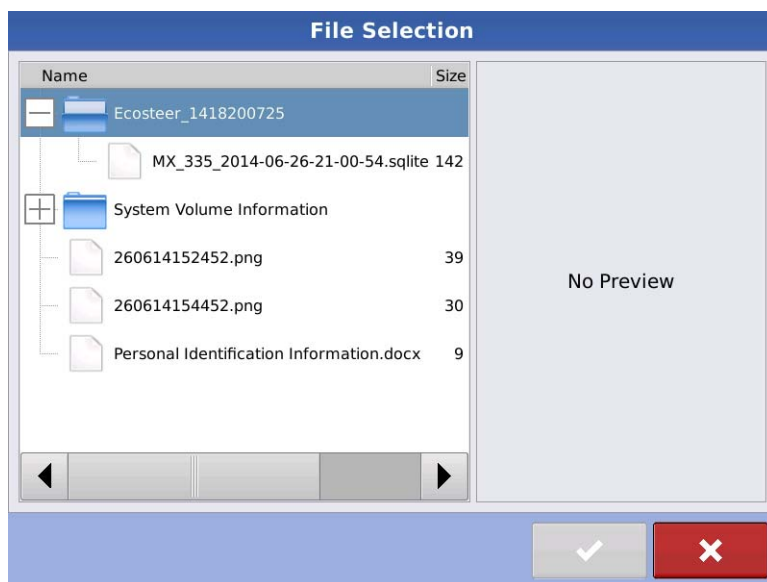

i NOTE!: After importing a vehicle it is required to complete Compass and Tilt Zero calibrations by pressing Auto Calibrate button in Vehicle Menu.

AUTO CALIBRATE

STEERING ADJUST

After vehicle has been calibrated, it should perform adequately for most normal field operations. However in some situations, it may be necessary to adjust steering performance to take into account field conditions, implement selection, traveling speed, etc. Steering Adjust screen enables user to adjust vehicle steering performance to match these changing conditions. You can change response of selected item by using slider bar.

To access Steering Adjust screens, press Steering Adjust button on AutoSteer Setup Vehicle screen.

Steering Adjust screen has following items that can be adjusted:

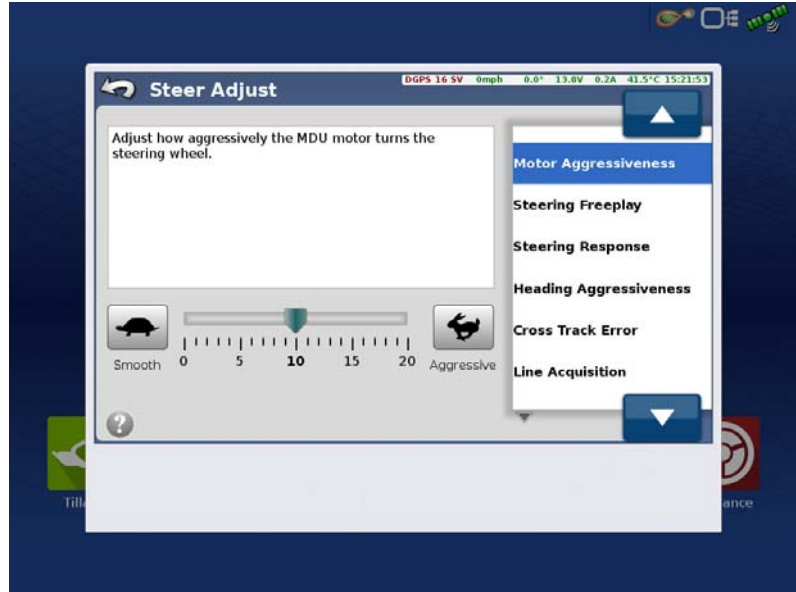

Motor Aggressiveness—This parameter adjusts how aggressively the MDU turns the Steering Wheel when it is commanded to turn.

Steering Freeplay—This parameter compensates for freeplay in the vehicle’s steering. Accounting for freeplay is most important at high speed. Too much freeplay compensation will lead to excessive steering wheel movement, especially at low speed. On the 0-20 scale, 0 is no freeplay compensation and 20 represents approximately 45 degrees or 1/8th of a turn of the steering wheel without tire movement.

Steering Response—Adjusts for oscillations of vehicle when it is on desired path.

Line Acquisition—Adjusts how aggressively vehicle steers onto desired steering path (A/B line). The goal is to tune system to take shortest route without excessively sharp or sudden movements of vehicle.

Heading aggressiveness—Adjusts how aggressively vehicle reacts to changes in vehicles heading.

Cross-Track Error—Adjusts how aggressively vehicle reacts to changes in cross-track error.

Reverse Response—Adjusts steering aggressiveness when vehicle is traveling in reverse.

Motor Response—Adjusts how aggressively the MDU motor turns the steering wheel.

Each item on Steering Adjust screen allows user to alter AutoSteering performance by allowing minor adjustments to control system. Item selected from list on right can be changed by moving slide bar using:



Moves bar towards turtle to slow response rate of steering system and makes slower smoother turns. If this value is moved too far to left, vehicle will get into a slow weaving pattern as it travels across field.



Moves bar towards rabbit to increase response rate of steering system. This causes system to react faster, however if value is moved too far to right, vehicle will get into a rapid oscillating pattern as it travels across field.



Press to make adjustments.



Move to increase/decrease response or directly select response rate to be adjusted.

STEERING COMPONENTS

This Steering Components screens allows user to view real time sensor reading to verify they are working, adjust sensitivity to some components, and test reaction of other components. These screens are used to test and manage all components related to system's interaction with vehicle.

To access Steering Components screen, press Steering Components button from AutoSteer Setup Vehicle screen.

ECU-S1

The ECU-S1 is the interface between steering sensors and actuators on vehicle. It receives information from Angle Sensor, pressure transducer, steering encoder, etc. and sends electrical signals to the hydraulic valve.

The ECU screen provides following diagnostic information:

Firmware Version—Version of software loaded on ECU.

Bootloader Version—Version of software that is loaded on ECU to allow it to boot up

Serial Number—Serial Number of internal ECU.

Manual Steering Override—A green light indicates AutoSteer system is detecting steering wheel motion or flow at flow switch. A red light indicates no motion or flow is detected.

Communication—If this light is green, system is communicating with the ECU. If this light is not green, there is a problem with the ECU.

MANUAL STEERING OVERRIDE

Manual Steering Override refers to the sensor that is used to detect when the operator manually turns the steering wheel. The AutoSteer system uses the manual steering override to know when the driver wants to take over steering manually. The Manual Steering Override screen shows the status of that sensor and allows the user to adjust sensitivity of the sensor.

The screen depends on vehicle profile detected. Refer to section that corresponds to sensor used for vehicle profile being used.

i NOTE!: It is important for Manual Steering Override to be functioning and set to proper level to allow user to disengage AutoSteer manually. Never operate an AutoSteer system without this feature working or set properly.

MDU-G4

The ECU-S1 detects manual steering override using feedback from the MDU-G4. In this screen the bar graph represents the current tested setting and pressing the – or + will adjust this bar graph.

After adjusting the manual override setting, pressing the start button will turn the steering wheel to the right and the setting can be tested. Once the setting is correct, pressing the Save Limit button will set the saved limit to match the tested limit.



MDU ACTUATOR

The MDU Actuator screen provides the user a way to command the Mechanical Drive Unit to turn left or right and confirm the AutoSteer system is properly controlling the MDU-G4. If the commands sent to the MDU-G4 are not functioning properly, check to make sure that the MDU-G4 switch is set to the “steer” position.

i NOTE!: Before performing this test, ensure people and objects are clear of the vehicle. When pressing the Steering Command buttons, the wheels or vehicle will move quickly from side to side. Press the STOP button to halt the vehicle steering movement.

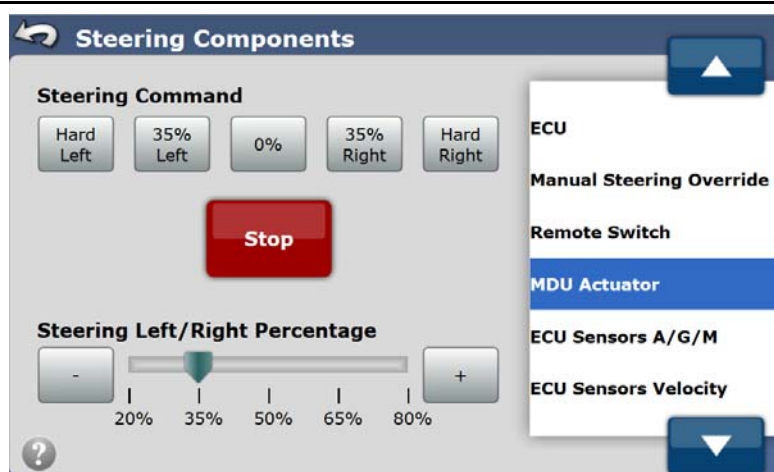

i NOTE!: For the MDU Actuator screen, the Steering Command buttons control the direction the Mechanical Drive Unit (MDU) rotates.

The following are the controls available on the Actuator screen:

Hard Left—Pressing this button tells the MDU to turn to the left at 100% speed.

xx% Left—The xx represents the Steering Left Percentage that the slider bar has been set to. Pressing this button will turn the MDU to the left at xx% speed.

0%—The MDU will not rotate.

xx% Right—The xx represents the Steering Right Percentage that the slider bar has been set to. Pressing this button will turn the MDU to the right at xx% speed.

Hard Right—Pressing this button tells the MDU to turn to the right at 100% speed.

Stop—Pressing this button stops all commands to the MDU.

Steering Left/Right Percentage—This slider controls the change percentage for the xx% Left and xx% Right buttons. Changing these values allows the user to test how the MDU reacts at different loads.

Minus (-) and Plus (+) Buttons—Pressing these buttons adjusts the Steering Left/Right Percentage Slider Bar.

REMOTE SWITCH

If a Remote Engage switch has been activated on the system, Steering Components screen will show an option for Remote Switch in list on right. Remote Engage switch must be enabled in Accessories screen before it is visible here. To enable or disable Remote Engage switch, see [“ACCESSORIES” on page 34](#). This screen will provide an indicator as to whether Remote Engage switch is being detected by the system.

Remote Switch screen:

Remote Switch—Indicator will turn green when Remote Switch is activated and turn gray when it is deactivated.

ECU SENSORS

ECU Sensors A/G/M screen provides raw data that ECU is measuring. ECU has a three axes Accelerometer, three axes Gyro, and three axes Compass. These sensors allow the ECU-S1 to determine Heading, Roll, and Pitch of unit.

ECU SENSORS VELOCITY

ECU Sensors Velocity screen provides data system is using for measuring velocity of system . This information helps technician to understand how system is operating.

SYSTEM TAB

System menu enables user to manage system level items. This includes providing an overview of system health, manage system wide settings, manage accessories that may be connected to system and upgrading to new software.

To access System menu, refer to your Display Operator's Manual for instructions on accessing AutoSteer Setup screens. Once there, select System tab.

System Health—Provides an overview of system and displays any issues that may be present.

Manage Settings—Manage log files, databases, or reset system back to factory defaults.

Accessories—Manage any accessories connected to the system.

Technician—Reserved for Service Technicians only. End users do not have access to this area.

Software Upgrade—New versions of firmware can be loaded onto the system.

System Log—Steering and GPS log entries that can be used in troubleshooting system.



SYSTEM HEALTH

System health screen provides quick diagnostic and status view for various aspects of the system. If a problem should occur, this allows user to take quick glance at status of various sensors and see if any obvious problems appear. If a problem exists, this will help troubleshoot what is not functioning properly.

To access different screens, use Blue Up/Down Arrows or buttons or directly select hardware group from list on right. Status for each item is shown by one of three icons:



Green Check—This indicates no problems detected.



Red X—This indicates there might be a problem or feature code has not been purchased for this item.



Exclamation Point—Indicates that component is not ready yet.

System Health Components are broken down into hardware groups. Items inside each group change based on which vehicle type is active.

Overview—Provides overview of the system and provides a quick glance at which group may be causing problem so it can be looked into more closely.

GPS—Items that have to do with getting a position, includes GPS signals and correction signals.

Steering—Items that have to do with interfacing with steering system.

Hardware—This group has to do with hardware error checks. Displays when sensor values fall outside normal or expected ranges.

Each item in group shows a specific item that is being monitored, a code that explains status, and a quick reference status symbol that quickly alerts user to good, bad, or possible problems. Additional items can be scrolled to in same screen by using Gray Up/Down Arrows at bottom of screen.

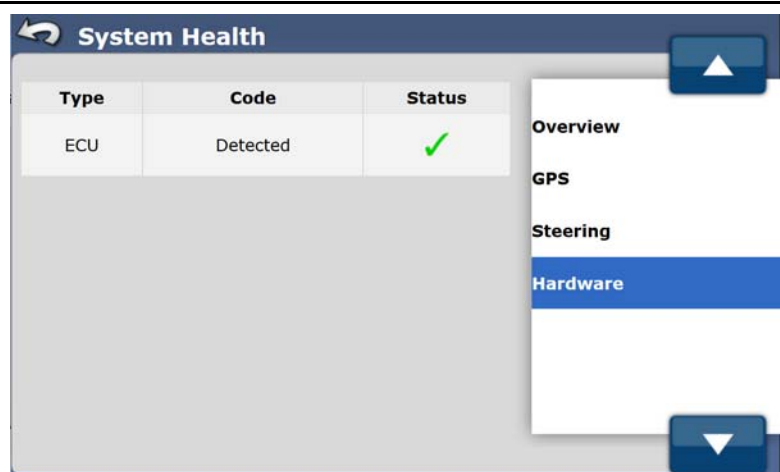

MANAGE SETTINGS

Manage Settings screens allow user to manage internal databases and logs files. Database stores all vehicle configuration, calibration, and history information for system. Log files keep a running list of everything the system has done. Manage Settings screens available are:

Log Files—Copy or Delete internal log files.

Database—Backup or Restore databases.

Reset Factory Default—Reset all settings back to default factory settings.

Shutdown Delay—Set amount of time to delay shut down.

History Files—Export logging diagnostic and troubleshooting information (at the request of support only).

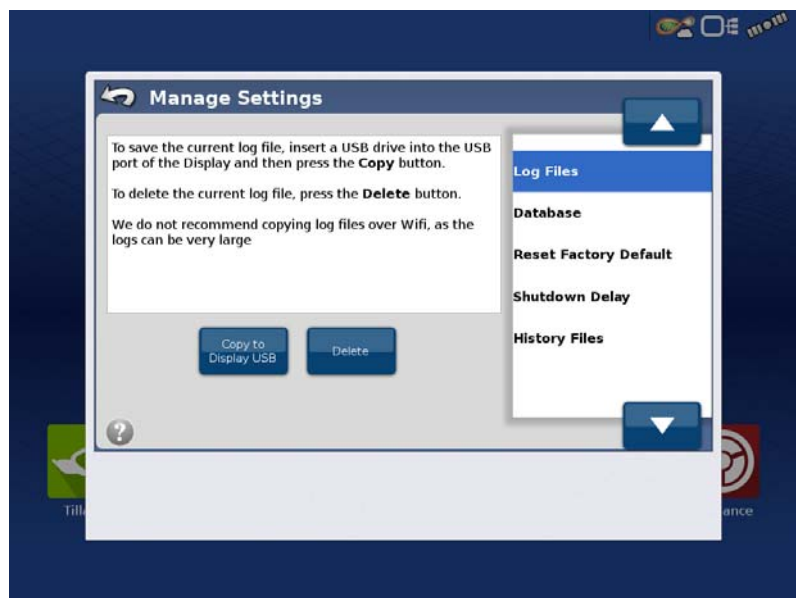

LOG FILES

System continually logs files stored internally on unit and records information while it is powered up. These log files contain GPS data, correction information, steering performance, errors, and configuration changes that are made over the duration of the log. Data is stored in 5 minute segments and can store up to five hours of past data. Once system fills its logging storage space, it begins to overwrite the earliest files with the latest.

Logs contain system data that can be used for diagnostic and troubleshooting purposes should a problem occur. If there is a problem, data can be copied to a USB drive from the system via Display USB. This data can then be sent to your AutoSteer dealer where they can get it analyzed. Most problems can be reproduced and solutions tested using data that is sent in. If necessary, software patches can be generated by manufacturer to quickly resolve issues that occur in field. There are two choices in Log Files section.

Copy to Display USB—Copies data to USB drive.

Delete—Deletes all log files stored in the system.

Copy to Display USB

i NOTE!: When using WiFi or Ethernet connection to a Tablet or Laptop, Tablet or Laptop is considered display

If an error occurs and your AutoSteer Dealer requests log files, follow procedure below to copy log files stored on system.

Insert a USB drive to Display USB port.

From System tab, press Manage Settings button, highlight Log Files from list on left, and then press Copy to Display USB button.



File Download Progress screen will now appear. Allow file to fully upload to USB drive.



When file download is 100% complete, press  to return to Log Files screen.

Delete

Sometimes it is advantageous to clear log files and then duplicate problem with a clean log. This allows copy procedure to proceed much faster as there is a lot less data to transfer. If it becomes necessary to delete log files, follow procedure below:

1. From System tab, press Manage Settings button, highlight Log Files from list on left, and then press Delete button.
2. A Warning message will appear.
3. To accept deleting log files, press . To cancel deleting log files, press .

i NOTE!: Delete logs files only if you can reliably replicate a problem and want to copy log files faster. If problem is not repeatable, do not delete log files, copy all of them so issue can be found. Be sure to record UTC time, and date that issue occurred before contacting your AutoSteer dealer.

4. When log files have been deleted, a confirmation screen will appear. Press  to accept it and to return to Log Files screen.

i NOTE!: It may take a few seconds to delete log files. Let it run for a minute and if it has not finished by then, press Previous Menu Arrow in upper, left corner of screen to end it.

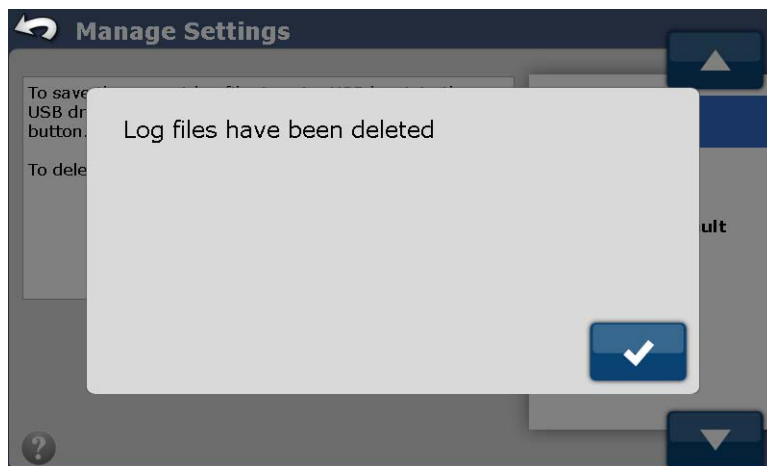

DATABASE

System stores all configurations, vehicle profiles, historical data, and other information in a database on internal memory. This database can be exported, saved, and used to restore back onto a system later if necessary. Database also contains important information that can be used by your AutoSteer dealer to help in troubleshooting.

There are two choices in Database section.

Backup to Display USB—Downloads current database on the system to USB Drive.

Restore from Display USB—Replaces current database on the system with database stored on USB drive. Database being restored must be from the same serial number and firmware version.

Shutdown Delay—Set Unit Shutdown Delay Time.

History Files—To copy the History Files, insert, if necessary, a USB drive into the Display's USB port and then press the **Copy to Display USB** button.



Backup to USB

It is a good practice to backup database on the system regularly. If database becomes corrupt or system needs to be replaced, system can be restored from backup quickly without having to redo all vehicle setups. To backup database, follow procedure below:

1. Insert a USB drive into the display USB port.
2. From System tab, press Manage Settings button, highlight Database from list, and then press Backup to Display USB button.
3. File Download Progress screen appears. Allow file to be uploaded to USB drive.
4. When file download is 100% complete, press . File has been successfully copied to USB drive.
5. Store backup in a safe place.

Restore from Display USB

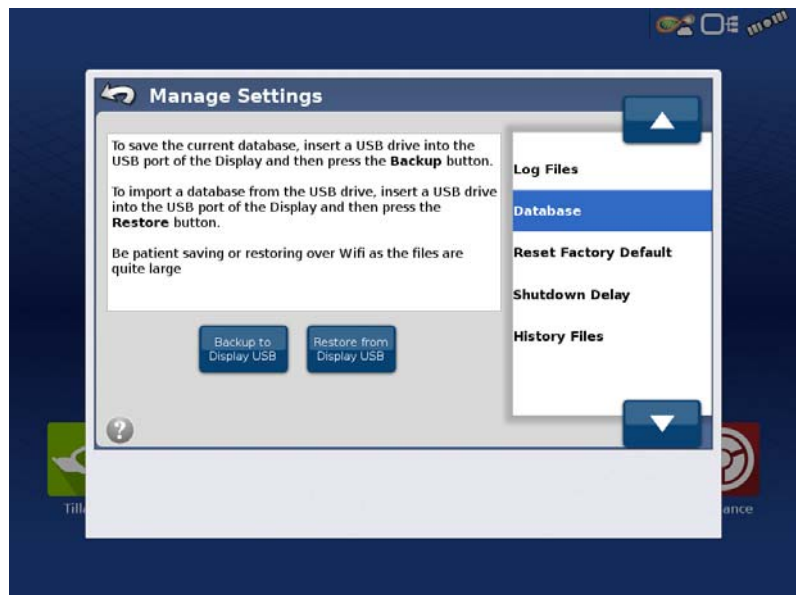

User can recover a system provided there is a saved copy of the database on a USB drive. To restore system database with a previously created backed up, follow procedure below:

-  NOTE!: All data on the system will be replaced with the database that is restored. All data will be lost on the system.
-  NOTE!: Database that is restored onto unit should come from same serial number and version of unit being restored on.

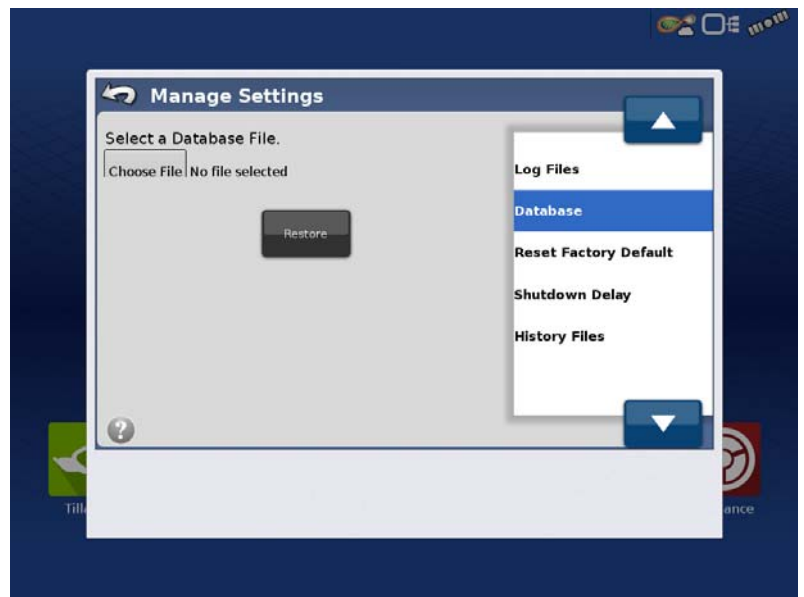

1. Insert USB drive with database to be restored into the display USB port.
2. From System tab, press Manage Settings button, highlight Database from list on left, and then press Restore from Display USB button.
3. Press Choose File button to locate database to import.



4. Navigate to file that is to be restored from USB drive and select by highlighting blue. Press  to select file. Press  to cancel.

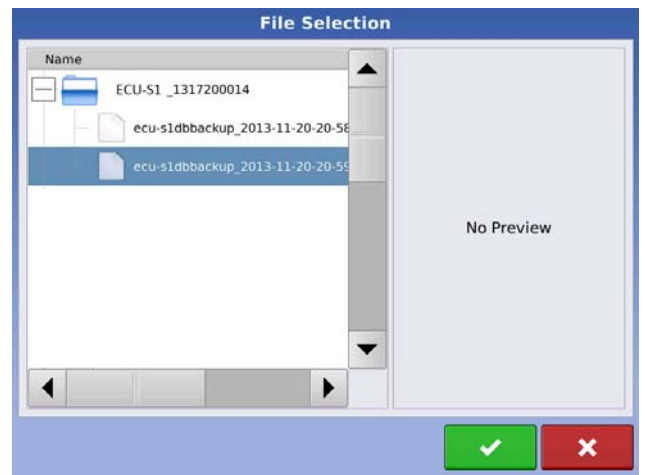

5. Once file has been selected, press Restore button to start process.

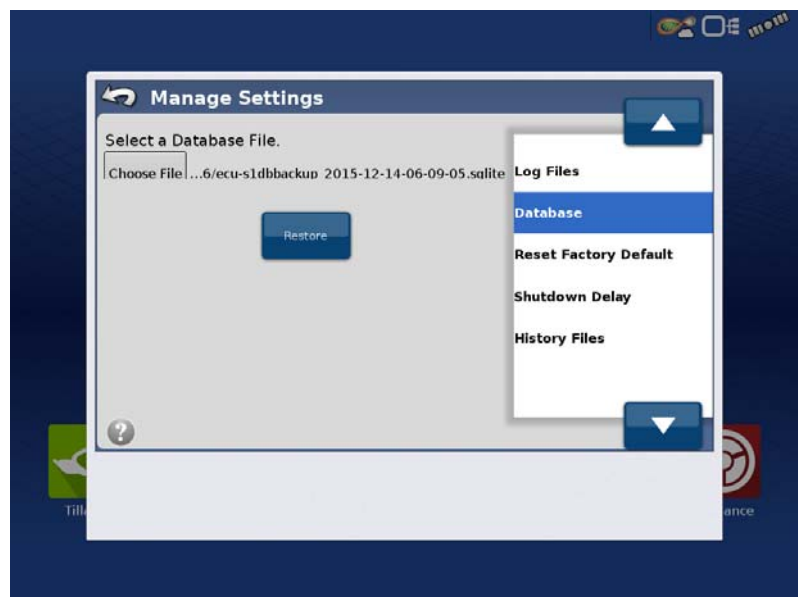

6. Restore will begin. Process will take a couple of minutes. **Do not touch system while restore is taking place.**

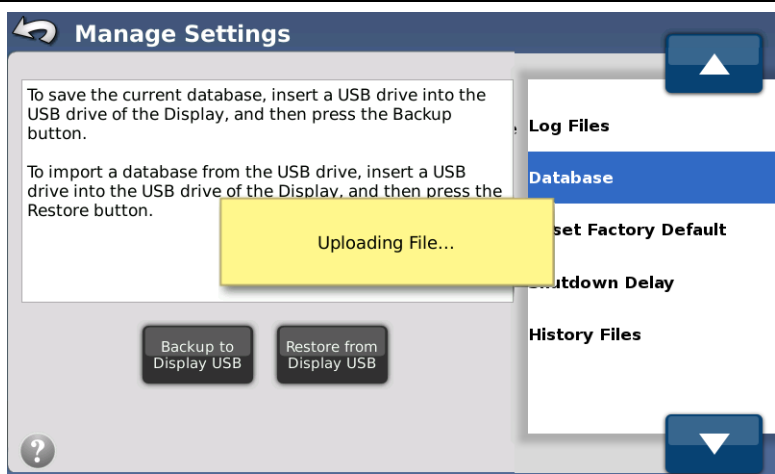

7. System will notify when database has been restored. Press  to acknowledge that restore is complete.

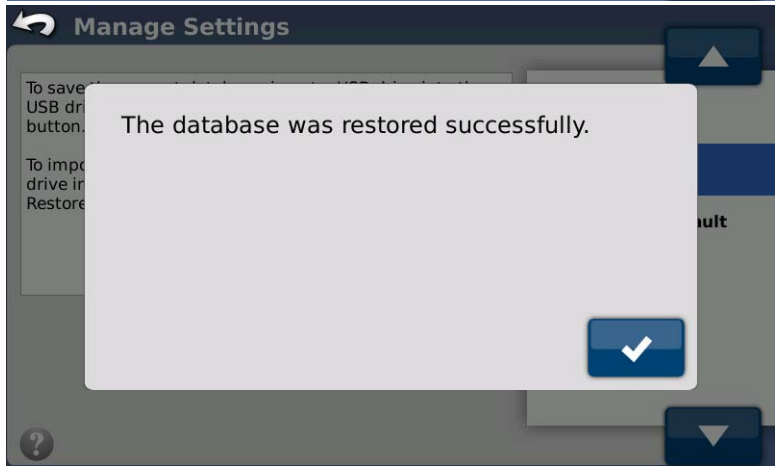

RESET FACTORY DEFAULT



There may be occasions when it is necessary to restore the system back to Factory Default settings. This could be necessary if system is transferred to a new owner, or database becomes corrupted on unit. If this becomes necessary, user can simply use Reset Factory Default feature. There is only one choice in Reset Factory Default section.

Reset—Returns system to factory default settings.

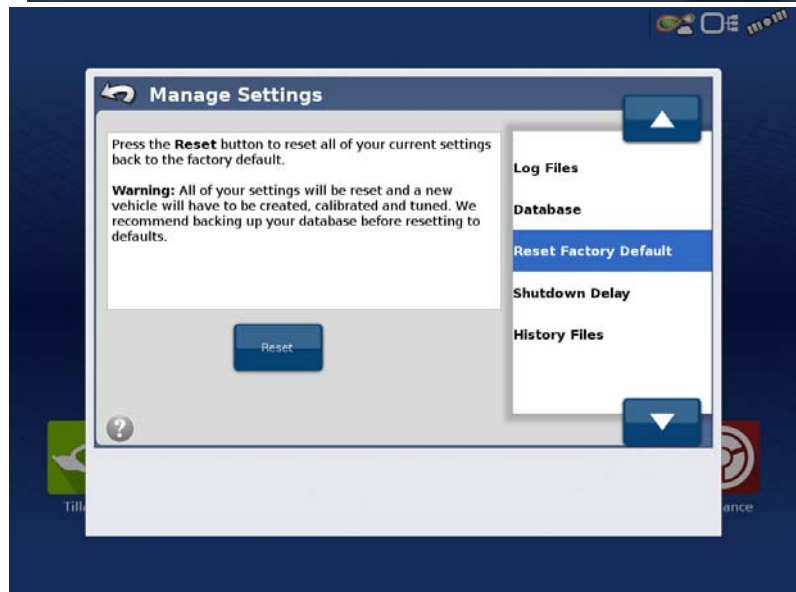
 **NOTE!** Resetting system to factory default will erase all current settings including vehicle profiles and GPS Configuration. Feature Codes are not affected by this process. It is strongly suggested to backup database using procedure provided on “Backup to USB” on page 27 prior to resetting to factory default settings.



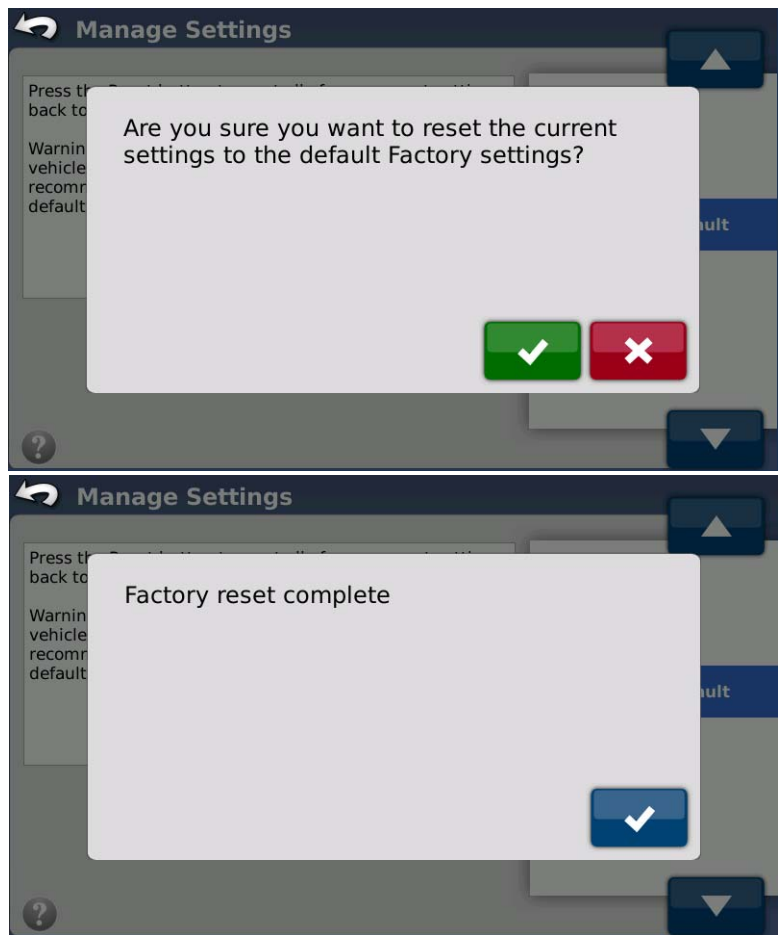

Reset

1. From System tab, press Manage Settings button, highlight Reset Factory Default from list on left, and then press Reset button.
2. Press  to start factory reset. Press  to cancel reset.
3. System will notify when factory reset is complete. Press  to acknowledge it. Reset is complete.



SHUTDOWN DELAY

Shutdown of ECU-S1 controller can be delayed 1-30 minutes using the Change Delay Time button.

1. Select time delay setting.
2. Press  to accept Shutdown delay change. Press  to cancel change.

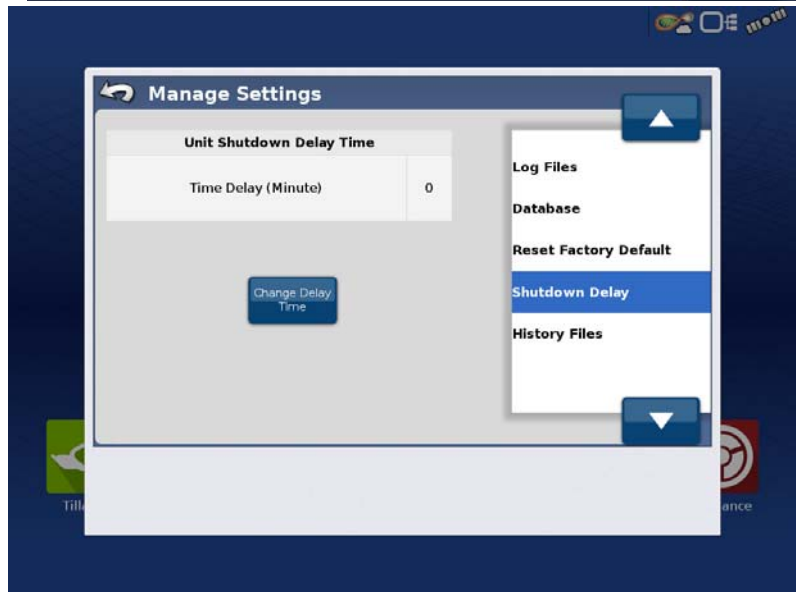

HISTORY FILES

Log files stored within the system. Enables technicians and service personnel to download system information for diagnostics and troubleshooting, at the request of support only. Copy to display USB.

ACCESSORIES

The system was designed to allow additional accessories to be developed and attached to it over time if new ones arise. Accessories menu is used to manage these optional attachments. Currently there are two options available for the system. As needs change, additional accessories may be added in the future. Accessories are:

Remote Switch Engage—Allows user to manage installation of a remote engage switch on they system.

Remote Switch Disengage—Allows user to disengage remote switch.

REMOTE SWITCH ENGAGE

Remote Switch Engage option allows user to connect an external device (foot switch, rocker switch, toggle switch, etc.) to system harness. User can then use external switch to Engage AutoSteer by pressing switch. This allows operator an easier way to engage AutoSteer so they do not have to reach up to the display in order to disengage autosteer.

Remote Switch Engage accessory is by default disabled. Remote Switch Engage accessory option will show user Current Status (Enabled or Disabled) of switch and provide user a way to change that status. This screen has one option:

Enable (Disable)—This button switches between two states after you push it. It enables or disables Remote Switch Engage Only option.

ENABLE (DISABLE)

To Enable or Disable Remote Switch:

1. From System tab, press Accessories button, highlight Remote Switch from list on left, and then press Enable (Disable) button.
2. Once Enable (Disable) button has been pressed, button will change to opposite of what it was and Current Status will be updated.

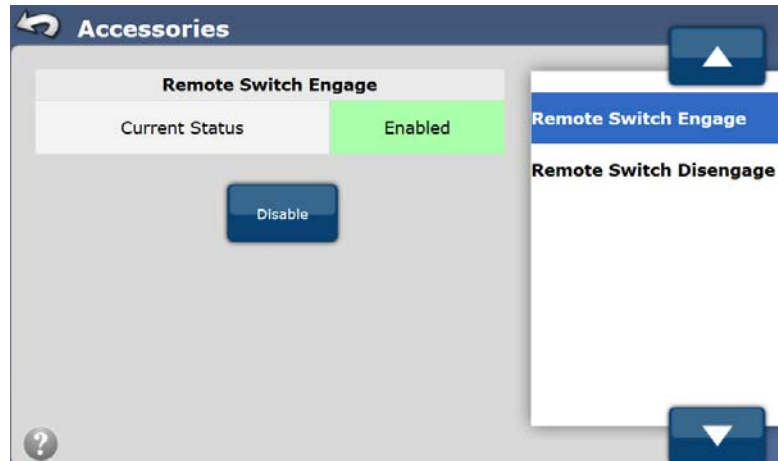

REMOTE SWITCH DISENGAGE

Remote Switch Disengage option allows user to connect an external device (foot switch, rocker switch, toggle switch, etc.) to system harness. User can then use external switch to Disengage AutoSteer by pressing switch. This allows operator an easier way to Disengage AutoSteer so they do not have to reach up to the display.

Remote Switch Disengage accessory is by default disabled. Remote Switch Disengage accessory option will show user Current Status (Enabled or Disabled) of switch and provide user a way to change that status. This screen has one option:

Enable (Disable)—This button switches between two states after you push it. It enables or disables Remote Switch Disengage Only option.

ENABLE (DISABLE)

To Enable or Disable Remote Switch Disengage:

1. From System tab, press Accessories button, highlight Remote Switch Disengage from list on left, and then press Enable (Disable) button.
2. Once Enable (Disable) button has been pressed, button will change to opposite of what it was and Current Status will be updated.

i NOTE!: If you wish to use remote accessory for engaging and disengaging autosteer system, both remote switch engage and remote switch disengage must be enabled

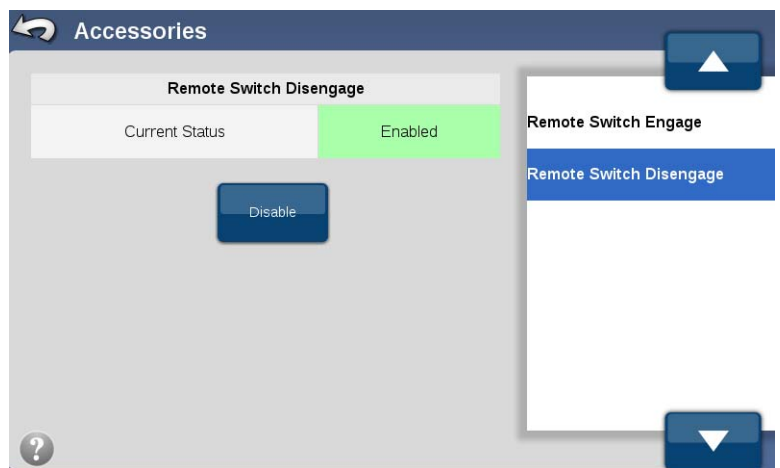

TECHNICIAN

Technician screen is password protected. Entry past this screen requires proper training and is only to be used by qualified service technicians. There are no normal operation options required by users in this screen.

SOFTWARE UPGRADE

i NOTE!: When using WiFi or Ethernet connection to a Tablet or Laptop Tablet or Laptop is considered display

Software Upgrade screen enables user to upgrade system to new versions as new application software bundles are released. Because new software bundles include fixes to known issues, it is recommended users upgrade their system to latest software release when:

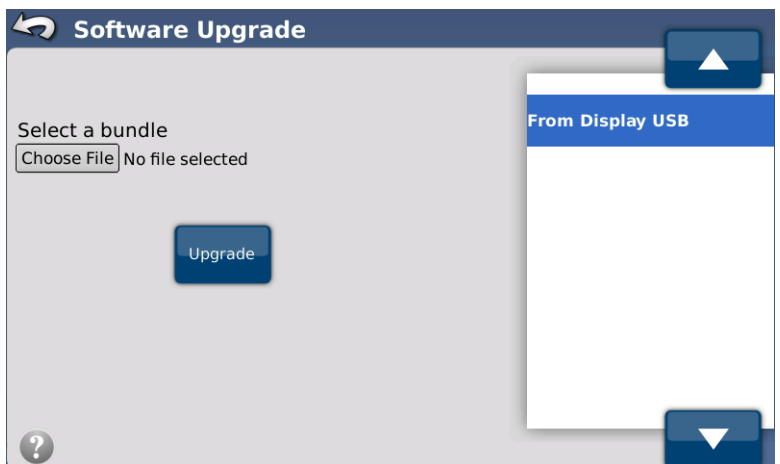

They experience issues that are known to be fixed on new software release.

Need features which are only available with an upgrade to latest software.



UPGRADE PROCEDURE

To upgrade system to the latest version:

1. Acquire latest upgrade file from your AutoSteer Dealer.
2. Save upgrade file onto a USB drive.
3. Insert USB drive with software bundle into display USB port.
4. From System tab, press Software Upgrade.
5. From Software Upgrade screen, press Choose File button.
6. Navigate to upgrade file on Disk and select it.
7. Press  to select file. Press  to cancel.

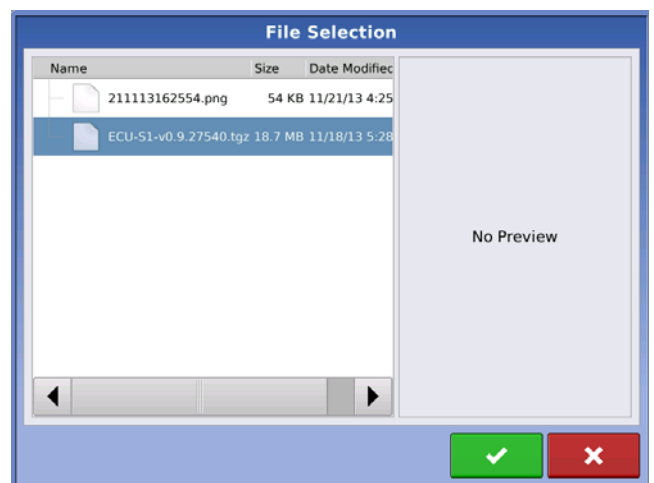

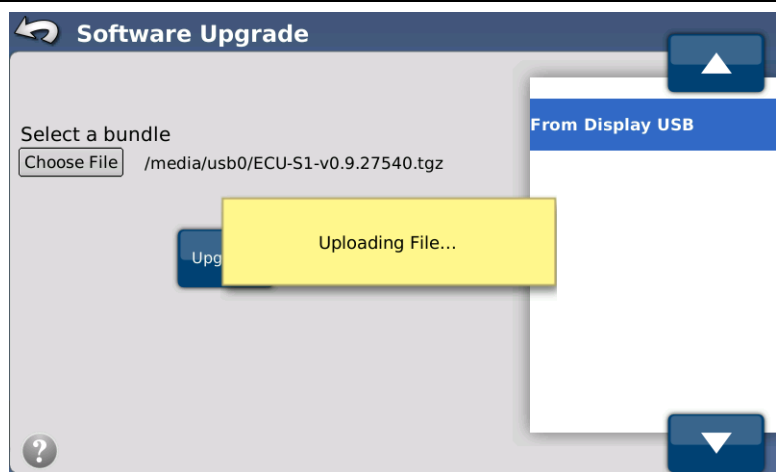

8. Press Upgrade button to begin upgrade.
9. System will begin upload of upgrade file to system. This process will last a minute or two.
10. System will then go through upgrade process and show progress of upgrade on screen. This process can take 10 to 15 minutes.

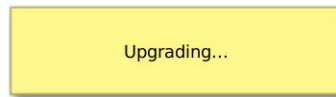

11. When upgrade is complete, ECU-S1 will reboot and then Upgrade complete screen will display.

Using ECU-S1-v0.9.27540.tgz
 ECU-S1 board detected.
 U-Boot upgrade not needed, actual version 27403
 Check initial condition prior to perform update
 Initial condition ok
 Updating step 1
 Updating step 2
 Updating step 3
 Updating step 4
 Updating step 5
 Update success
 ECU-S1 rebooting
 please wait



12. Press  to acknowledge. Upgrade is complete.

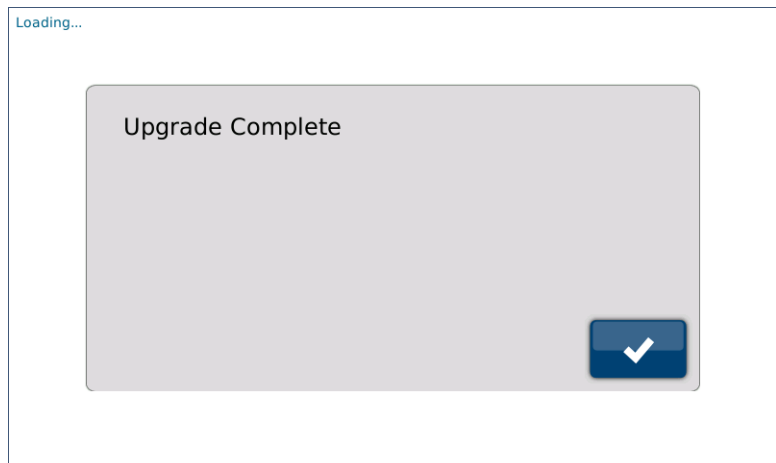

SYSTEM LOG

System Log menu will display steering or GPS information that can be used for troubleshooting.

i NOTE!: Contact your autosteer dealer for assistance with any System Log information

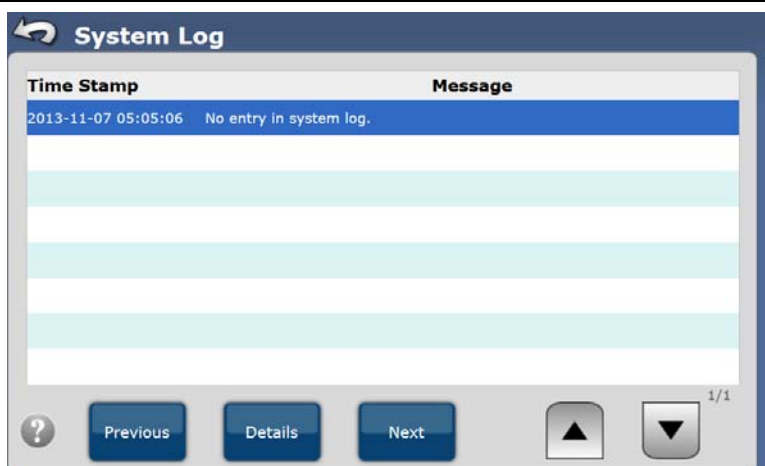

GPS TAB

GPS DIAGNOSTICS

The GPS Diagnostics screen provides information about the quality of the GPS signals. The information provided can help to troubleshoot GPS problems. There are two options available in the GPS Diagnostics screen:

General—Provides the basic information about the GPS data.

NMEA Messages—Displays real-time GPS data received by the ECU-S1.

NMEA Status—Provides GPS source and rate information.

Fix Details—Provides GPS position fix details, base station id update, and time since last correction.

GENERAL

The General screen displays the status of a number of operations. Parameters are explained below:

GPS Mode—The current GPS mode the system is operating in.

PDOP—(Positional Dilution of Precision) is a measure of the strength of the satellites scatter. When the satellites are close together, their geometry is not favorable for position calculations and the PDOP value is high; when their geometry is favorable and they are far apart, the PDOP value is low. Thus a low PDOP value represents a better GPS positional accuracy.

Heading—Displays the heading the vehicle is facing or traveling in degrees.

Height—Shows the Vehicle’s altitude above sea level.

of Satellites—Displays the number of satellites being tracked by the system.

Vehicle Position—Not currently used.

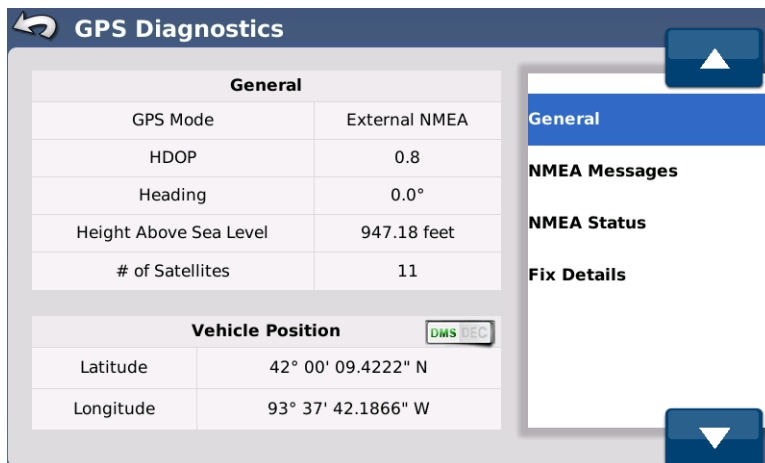

NMEA MESSAGES

The NMEA messages screen displays the Raw NMEA messages that the OnTrac3 system is receiving from the GPS receiver.

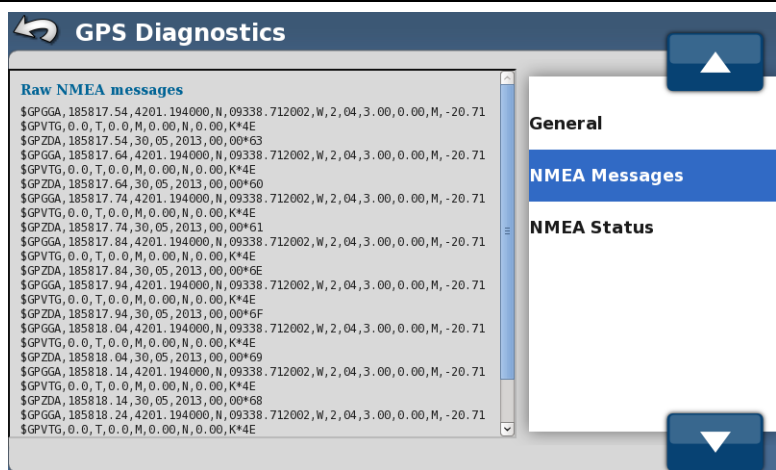

NMEA STATUS

The GPS Status screen displays the status and configuration of the NMEA messages received from the GPS receiver.

Message—Type of message received CAPI or NMEA

Rate(Hz)—The hertz rate the message is being received at

Decimals—The number of decimal points it is receiving from the NMEA string

Quality—The quality of signal it is receiving. RTK, WAAS, OmniSTAR

Status—The status of the signal quality

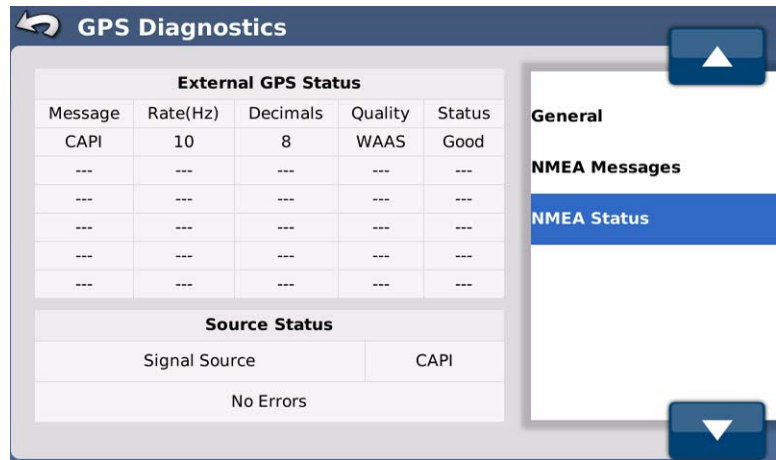

FIX DETAILS

Not Currently used

Base ID—ID of Base Station Receiver is connected to time from last correction, is the correction age of RTK signal from base station.

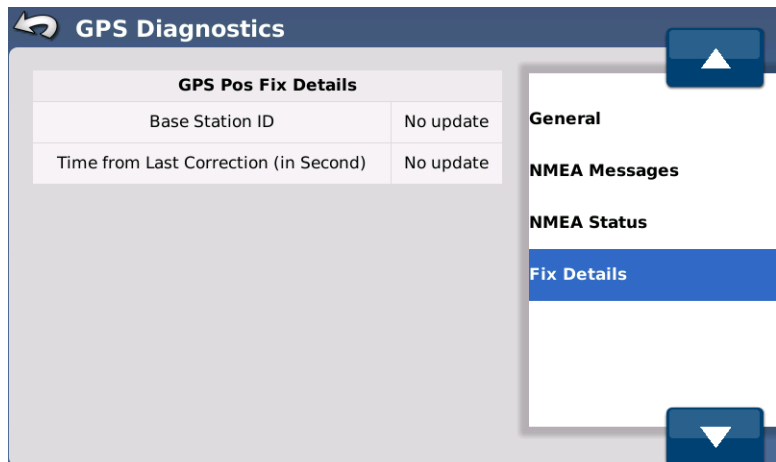

GPS PRECISION SETTINGS

RELAX DOP FOR STEERING

Allows steering with PDOP levels greater than 3
(This may result in degraded steering performance).

Enabled—Allow steering when PDOP is less than 5.

Disabled—Will not allow steering when PDOP is greater than 3.

Relaxed DOP is useful in areas with high DOP values or in areas that experience scintillation.

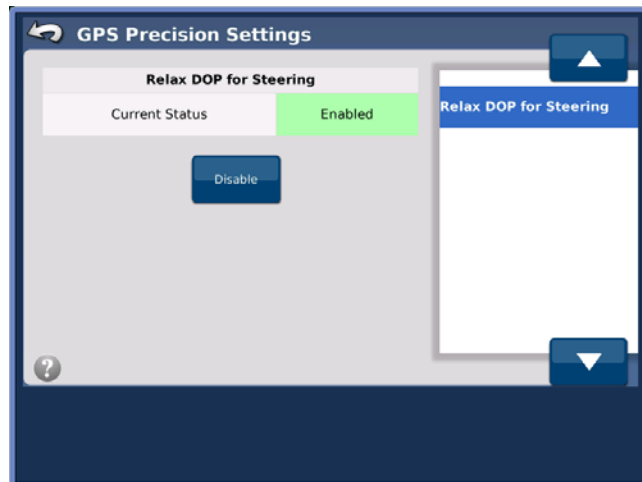

NMEA OUT

i NOTE: This feature configures the ECU-S1 serial port to output roll corrected NMEA messages. Make sure that you have the correct wiring harness connected to ECU-S1 to route these messages. Please contact your dealer for further details.

The NMEA Out screen enables user to configure NMEA 0183 message for output from the system for use by 3rd party precision agriculture controllers. There are four options that can be configured in this screen:

NMEA-Out Messages—This configures which NMEA messages are turned on and at what rate they are sent.

NMEA-Out Port Configuration—This configures the serial port settings.

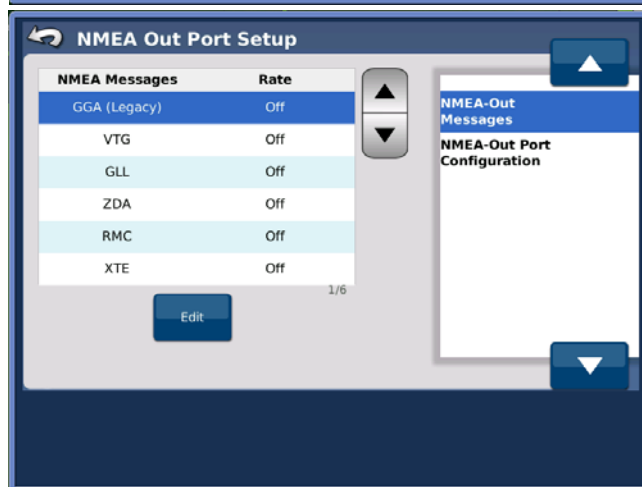

To access the NMEA Out screen, press the NMEA Out button at the GPS screen.

NMEA-OUT MESSAGES

i NOTE: Refer to your precision agriculture controller's documentation to determine the correct NMEA message and Baud rate is required to communicate. An incorrect setting may cause your controller to malfunction or not work at all.

The NMEA-Out Messages screen allows the user to configure which messages are sent out and at what speed.

The system supports the following NMEA message formats:

GGA, VTG, GSV, GLL, ZDA, RMC, XTE

The system supports the following data rates:

Off, 0.1 Hz, 0.2 Hz, 1 Hz, 5 Hz, 10 Hz

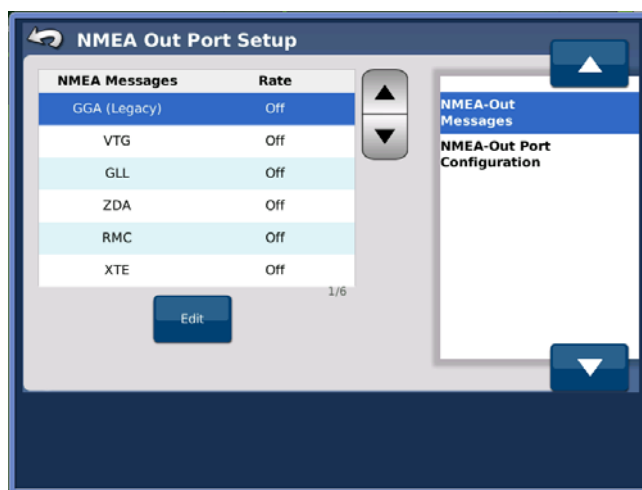

i NOTE: For OnTrac3, the quality indicator in GGA string will always display as SBAS, regardless of GPS correction source. For example, RTK will show as a quality of "2" even though RTK is being output by the ECU-S1.

MESSAGES CONFIGURATION

To change the configuration of any of the NMEA Message follow the procedure below:

1. Use the Gray Up/Down Arrow buttons or directly select the NMEA Message that is to be modified.
2. Press the Edit button.

3. Using the Gray Up/Down Arrow buttons or directly select the desired data rate.

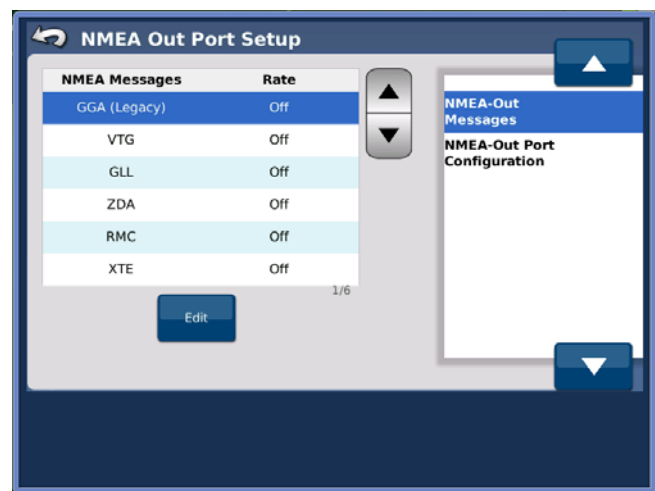

NMEA-OUT PORT CONFIGURATION



NOTE: Refer to your precision agriculture controller's documentation to determine the correct Baud Rate and Format that is required to communicate. An incorrect setting may cause your controller to malfunction or not work at all.

The NMEA-Out Port Configuration screen allows the user to configure the baud rate of the serial port.

The system supports the following Baud Rates:

4800, 9600, 19200, 38400, 57600, 115200

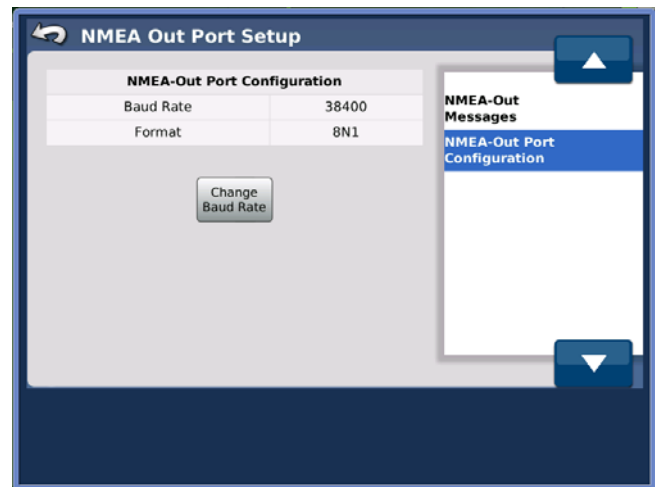

PORT CONFIGURATION

i NOTE!: Changing the Baud Rate on the NMEA Out screen also changes the Baud Rate for the External Radio input. Port A can be used simultaneously for the External Radio In and NMEA Out, however both functions must use the same Baud Rate.

To change the Port Configuration, follow the procedure below:

1. Press the Change Baud Rate button.
2. If adjusting Port A, a Warning message will appear. Press the Green Check button to accept it or the Red X button to cancel.
3. Use the Gray Up/Down Arrow buttons or directly select the desired baud rate. Press the Green Check button to accept changes or the press the Red X button to cancel.

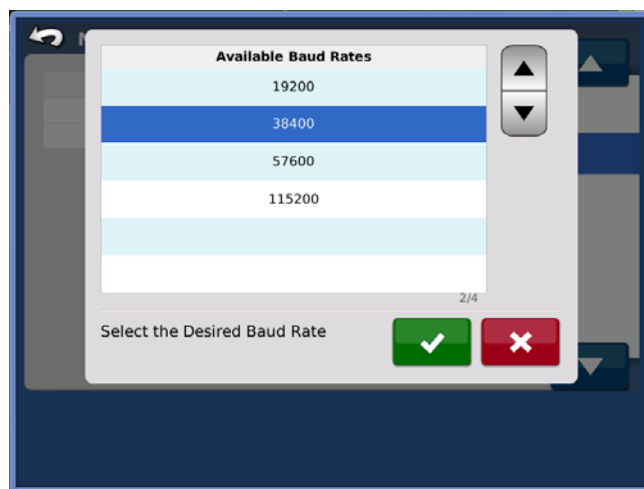

CONNECTIONS TAB

Connections tab displays available connections options

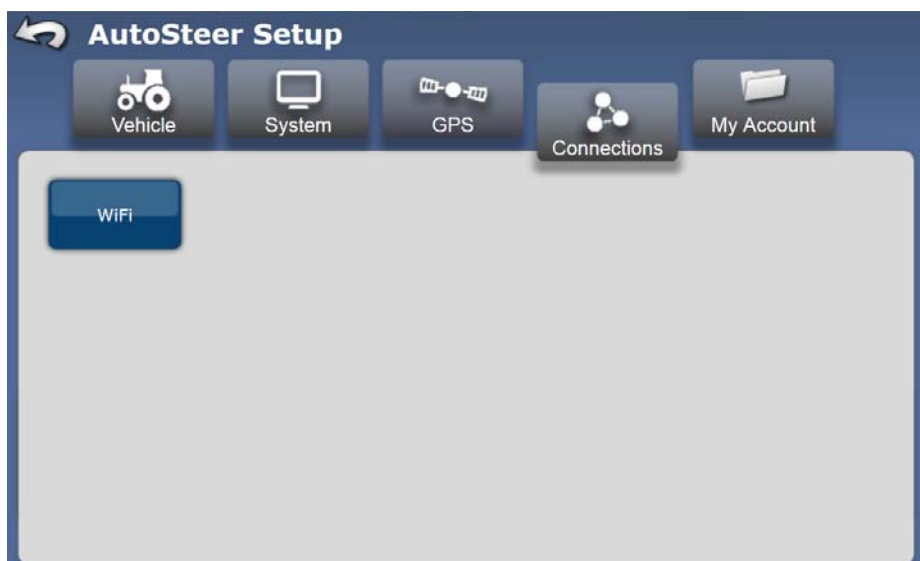

WiFi

WiFi Configuration screen displays status of system WiFi modem.

Current Status—Displays status of WiFi modem Enables/Disabled.

ESSID—(Extended Service Set Identification) Displays name of WiFi connection.

WiFi Firmware Version—Displays WiFi firmware version.

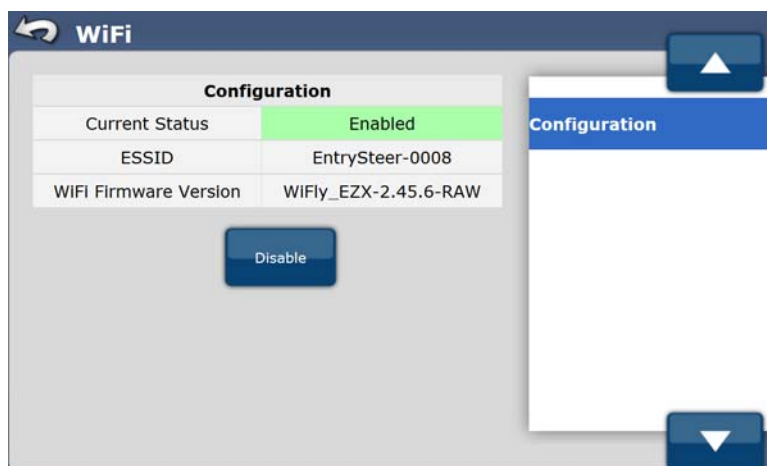

DISABLE button—allows operator to enable or disable WiFi connection.

When operator presses DISABLE button a warning will be displayed warning operator that disabling WiFi will cause certain functions to stop functioning.

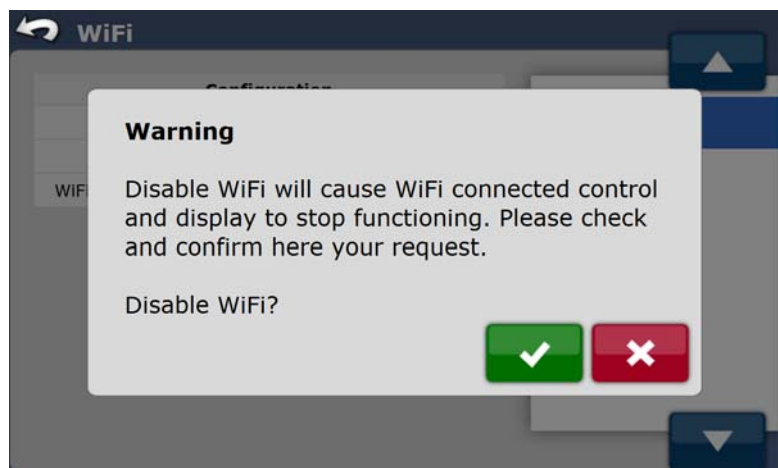

If WiFi connection has been disabled operator can Enable WiFi connection by pressing Enable button.

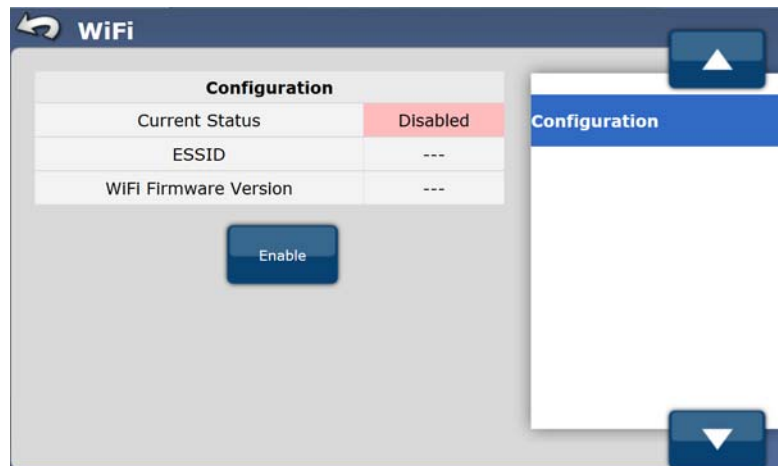

MY ACCOUNT TAB

My Account menu provides access to steering controller details and feature codes

Details—Gives user access to detailed summary of information about system components.

Feature Code—Not used but allows for future upgrades.

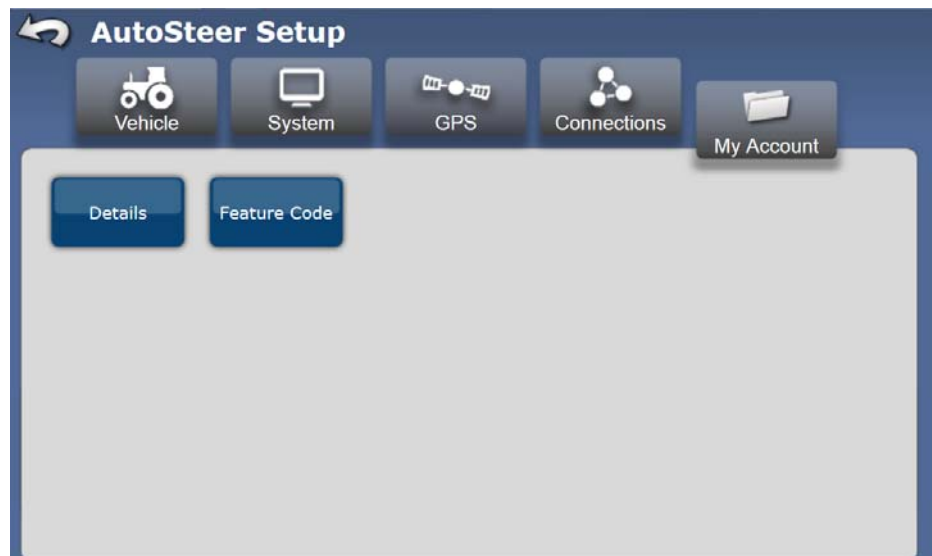

DETAILS

Details screen provides detailed information that may be required by support personnel when support is requested.

System—Provides loaded Software Version, Serial Number, and Warranty Key for System Unit.

Internal ECU—Provides Firmware Version, Serial Number, and type of ECU.

Display—Provides Software Version, Serial Number, and Display Type.

Proprietary Notices—Provides legal notices.

To access Details screen:

From My Account menu, press Details button.

Use Blue Up/Down Arrows or directly select item to view in Details screen. Information about selected item will appear.



 NOTE!: If a device is not present or not working properly, data for each device will show blanks.

FEATURE CODE

Feature Code screen displays all optional features that can be added to the system. These Feature Codes can be purchased at any time. Feature Codes add additional capabilities and functionality to the system that may be useful to the owner.

Feature Code screen displays all available Feature Codes, when they expire, and current status. User is given options to enable Feature Codes that have been purchased. Expiration date can show:



Activated—The feature code is valid and has an expiration date.



Never Activated—The feature code has never been activated.



Expired—The feature code was activated but has already expired.

ACTIVATING A FEATURE CODE

To activate a new Feature Code:

1. From My Account menu press Feature Code button.
2. Use Gray Up/Down Arrow buttons or directly select an item you wish to activate.
3. Press Edit button.

Enter Feature Code and press  to accept Feature Code or press  to cancel.

If code entered is valid, a dialog box appears informing user that Feature Code has been successfully activated. Press



to return to My Account menu.



NOTE!: In some cases, system must be powered down and then restarted after Feature Code has been activated to take advantage of new feature. Always power cycle system after activating new Feature Code.

Technical Specifications and Safety Notifications

English

OnTrac3 System

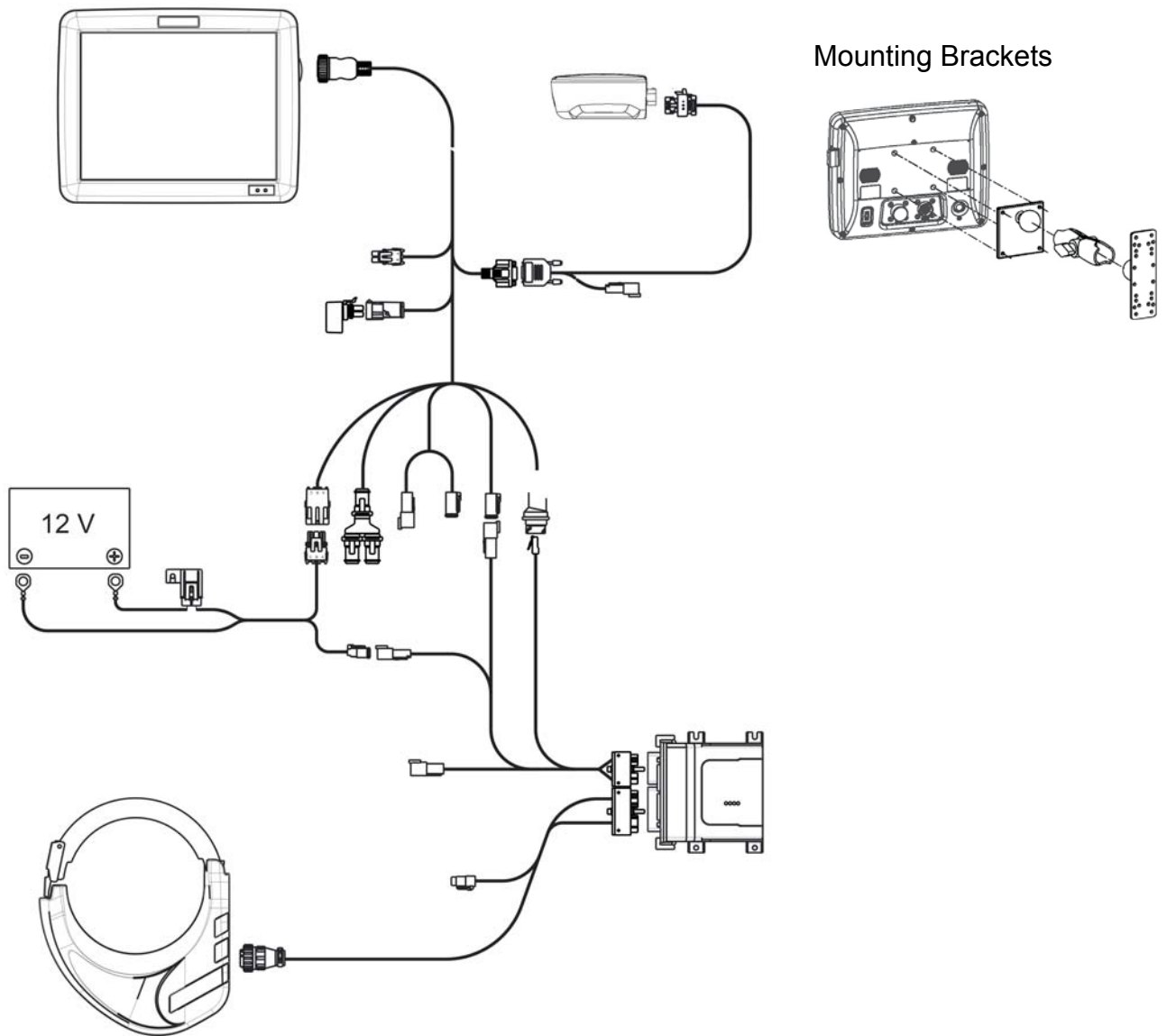

<p>Fuse Type Blade Style (ATO/ATC) 5 A rating 15 A rating Operating Voltage 9-16 V DC Max Current Rating Ag Leader Integra 4.0 A Versa 2.5 A</p>	<p>Technical Specifications Do not exceed the specifications below:</p> <ul style="list-style-type: none"> • Storage Temperature: -4° to +176°F (-20° to +80°C) • Operating Temperature: 14° to +156°F (-10° to +70°C) • Environmental Protection Rating: IP64 • No Protective Grounding required • Use 150V minimum insulation rating for external circuits
--	---

Safety Notice: Read these safety instructions and the User Manuals thoroughly, and follow the instructions.

Steering System refers to the OnTrac2 GPS Assisted Steering System and/or the OnTrac3 GPS Assisted Steering System and/or the ParaDyme system and/or the GeoSteer system.

- Only an operator who is fully authorized to drive the vehicle can use the Steering System.
- The operator must not exceed the safe speed limit for the terrain on which the vehicle is operating.
- The operator must always be aware of his actions when operating the Steering System.
- When installing the Steering System do not force the components as this can result in damage to the components.
- Always follow the instructions in the installation, operation, and maintenance manuals.
- Only trained personnel should install the Steering System.
- Always inventory the components delivered to ensure all the correct components are present. Never use replacement components. Only use original components.
- If there are any questions regarding the safe operation of the Steering System or the instructions in the manuals, immediately contact your authorized dealer or technical support.
- Always use the correct tools to install the Steering System.
- To prevent injury, use caution when installing the Steering System.
- Do not use or operate the Steering System in unsafe weather conditions.
- Do not use or operate the Steering System on unsafe terrain.
- Only an operator who is trained, experienced or authorized can use or operate the Steering System.
- Before using the Steering System, the operator must have sufficient knowledge of how to operate the systems in a safe manner.
- When installing the Steering System, all safety precautions must be clearly understood. If there are any loose, missing or damaged parts they should not be used.
- Before using the Steering System, verify all functions are checked and controlled to ensure they are working correctly. When there is any doubt, do not take any risks - always contact your authorized dealer or technical support.
- Before operating the Steering System, verify all functions of the Operator Presence Switch to ensure it functions correctly.
- Powering the Steering System ON or OFF must be done by following the correct prescribed procedures.
- If any vehicle or system function is abnormal, for example if excessive vibrations or noise occur, immediately stop the vehicle, power OFF the Steering System and contact your authorized dealer or technical support.
- When maintaining or cleaning the Steering System, it must be completely powered OFF and are free of any electrical currents.
- The operator of the Steering System in conjunction must read and understand all safety instructions so they can react in case of an emergency.
- The authorized dealer must always carry out maintenance or repairs on the Steering System.
- During repair or replacement of components on the Steering System, only original components must be used.
- Operator or maintenance personnel must always wear the correct personal protection equipment when working on the Steering System.
- Maintenance personnel must always use the recommended cleaning materials and accessories when the Steering System is cleaned.
- Unsafe conditions or situations with the Steering System must be reported to your authorized dealer or technical support.
- Objects cannot be placed on or in the area of the Steering System.
- During installation, calibration, and tuning of the Steering System the vehicle wheels may turn to the left and right. Be sure all people and obstacles are clear of the wheels before proceeding.
- Put the vehicle seat and steering wheel in the normal operating position and verify that Mechanical Drive Unit does not interfere with any controls.
- The operator must read and acknowledge the Automatic Steering Liability Notice each time the system is powered ON.
- If there are any questions regarding the safe operation of the Steering System or the operating instructions, contact your authorized dealer or technical support.
- The operator must keep alert for obstacles in the path of the vehicle. The Steering System cannot identify or avoid obstacles.
- The operator must remain in the operator's chair in the vehicle while the Steering System is engaged.
- Only use the Steering System in an open field. The systems must be powered OFF when the vehicle is on any type of roadway.

Liability Notice Novariant B.V. cannot be held responsible or liable in any way for any damages and / or accidents that occur through the malfunction of the machine on which it is installed, malfunction of the machine components, machine attributes (e.g. trailers), third party interference(s) or acts of the operator outside the intended use such as prescribed by Novariant B.V.

COPYRIGHT NOTICE Ag Leader Technology has copyrighted (©2014) the contents of this publication and the operating program for the Ag Leader Integra and Versa systems. No reproductions may be made without first obtaining the consent of Ag Leader Technology.

Dansk (Danish)

OnTrac3 system

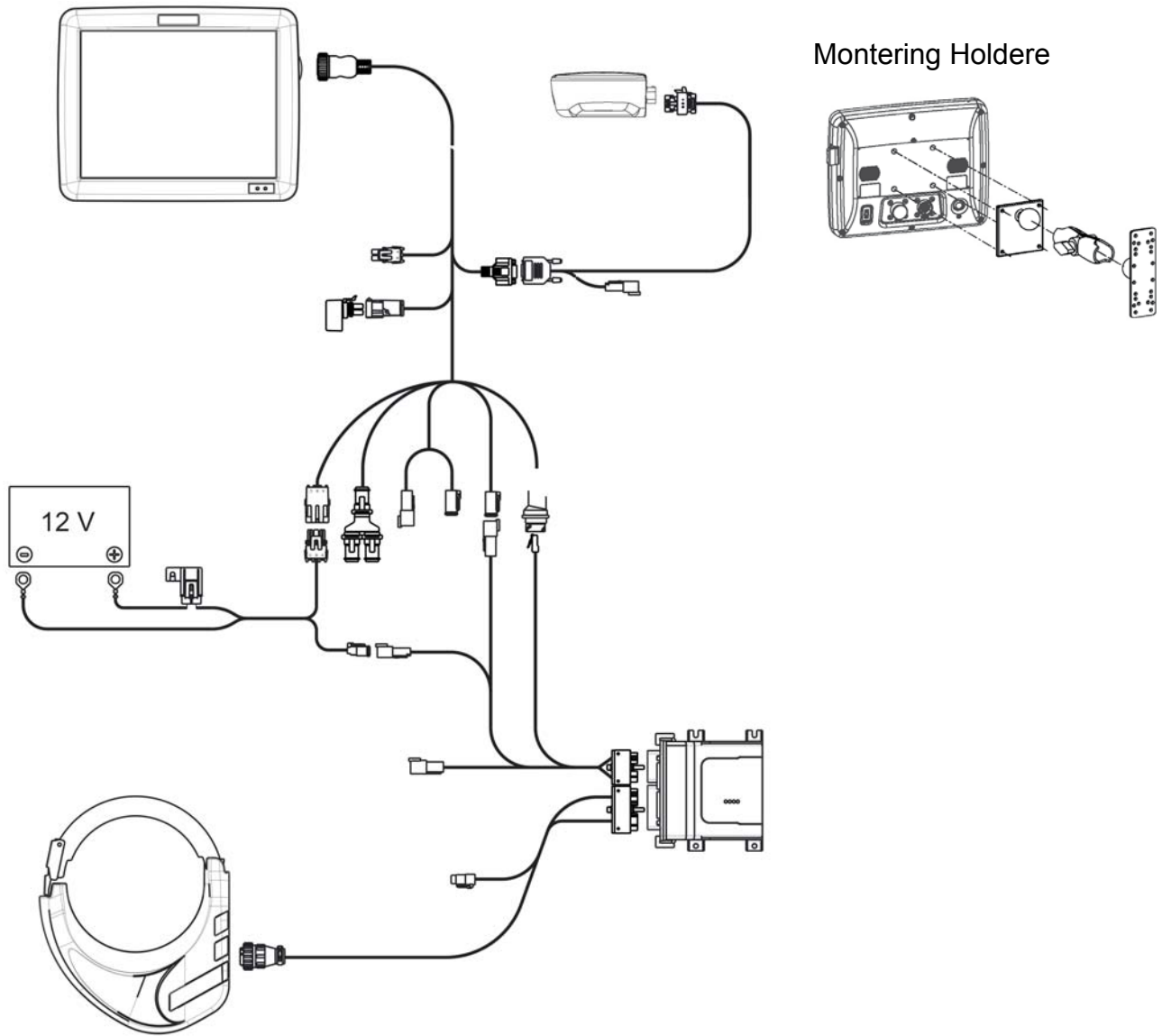

Sikringstype	Tekniske specifikationer
Bladstil (ATO/ATC)	Gå ikke ud over specifikationerne nedenfor:
Klassificering: 5 A	• Opbevaringstemperatur -20° til +80° C (-4° til +176° F)
Klassificering: 15 A	• Driftstemperatur: 10° til +70° C (14° til +156° F)
Driftsspænding:	• Klassificering for miljømæssig beskyttelse: IP64
9-16 V DC	• Der kræves ikke beskyttende jordforbindelse
Nominel maksimal strøm	• Brug minimum en 150 V isoleringsklassificering for eksterne kredsløb Sikkerhedsmeddelelse: Læs disse sikkerhedsvejledninger og brugervejledninger grundigt, og følg vejledningerne.
Ag Leader Integra 4,0 A	
Versa 2,5 A	

Sikkerhedsmeddelelse: Læs disse sikkerhedsvejledninger og brugervejledninger grundigt, og følg vejledningerne.

Styringssystem refererer til det assisterede styringssystem med OnTrac2 GPS og/eller det assisterede styringssystem med OnTrac3 GPS og/eller ParaDyme-systemet og/eller GeoSteer-systemet.

- Styringssystemet må kun bruges af en operatør, der er fuldt ud autoriseret til at køre køretøjet.
- Operatøren må ikke overstige hastighedsgrænsen for sikker kørsel for det terræn, hvor køretøjet bruges.
- Operatøren skal altid være opmærksom på hans/hendes handlinger under brug af styringssystemet.
- Under installation af styringssystemet må komponenterne ikke forceres, da det kan beskadige komponenterne.
- Følg altid vejledningerne i installations-, brugs- og vedligeholdelsesvejledningerne.
- Installationen af styringssystemet må kun udføres af uddannet personale.
- Kontroller altid ved modtagelse af forsendelser, at alle bestilte dele er modtaget, for at sikre, at alle de korrekte dele er tilstede. Brug aldrig andre komponenter som erstatning. Brug kun originaldele.
- Hvis der er spørgsmål angående sikker brug af styringssystemet, eller omkring vejledningerne i vejledningen, skal du straks kontakte din autoriserede forhandler eller teknisk support.
- Under installation af styringssystemet skal man altid bruge det korrekte værktøj.
- For at undgå personskader skal man være forsigtig under installation styringssystemet.
- Brug ikke styringssystemet i vejrforhold, der skaber usikre arbejdsforhold.
- Brug ikke styringssystemet i vejrforhold, der skaber usikre arbejdsforhold.
- Styringssystemet må kun bruges af en operatør, der er uddannet, har erfaring eller er autoriseret.
- Inden styringssystemet bruges, skal operatøren have tilstrækkeligt med viden om, hvordan systemerne betjenes på sikker vis.
- Alle sikkerhedsforanstaltninger skal være forstået ved installation af styringssystemet. Hvis der er løse, manglende eller beskadigede dele, må de ikke benyttes.
- Inden brug af styringssystemet skal det verificeres, at alle funktioner er blevet kontrolleret for korrekt funktion. Hvis der er tvivl om nogen ting, må der ikke fortsættes. Tag ingen risiko - kontakt altid din autoriserede forhandler eller tekniske support.
- Inden brug af styringssystemet skal det verificeres, at alle funktioner for kontakten for operatørens tilstedeværelse fungerer korrekt.
- Tænding og slukning af styringssystemet skal gøres på korrekt vis, efter de beskrevne procedurer.
- Hvis nogen af køretøjets eller systemets funktioner er unormale, hvis f.eks. der er overdrevne vibrationer eller støj, skal køretøjet straks stoppes, og styringssystemet skal slukkes. Kontakt din autoriserede forhandler eller teknisk support.
- Under vedligeholdelse eller rengøring af styringssystemet skal de være helt slukkede og den elektriske strøm skal være afbrudt.
- Operatøren af styringssystemet skal læse og forstå alle sikkerhedsvejledninger, så han/hun ved, hvad de skal gøre i en nødsituation.
- Den autoriserede forhandler skal altid udføre vedligeholdelse eller reparationer på styringssystemet.
- Under reparation eller udskiftning af komponenter i styringssystemet må der kun bruges originaldele.
- Operatør og personale, der udfører vedligeholdelsen, skal altid være udstyret med korrekt personligt beskyttelsesudstyr når der arbejdes på styringssystemet.
- Personalet, der udfører vedligeholdelsesarbejdet, skal altid bruge de anbefalede rengøringsmidler og tilbehør når styringssystemet rengøres.
- Usikre forhold eller situationer omkring styringssystemet skal rapporteres til din autoriserede forhandler eller teknisk support.
- Der må ikke anbringes objekter på eller i området for styringssystemet.
- Under installation, kalibrering og tuning af styringssystemet kan det forekomme, at køretøjets hjul drejer til venstre og højre. Sørg for, at alle personer og objekter holdes væk fra hjulene inden der fortsættes.
- Sæt køretøjets sæde og rat i normal driftsposition og verificer, at MDU (Mechanical Drive Unit) ikke griber forstyrrende ind i kontrolanordningernes funktion.
- Operatøren skal læse og acceptere ansvarserklæringen for den automatiske styring, hver gang systemet tændes.
- Hvis der er spørgsmål angående sikker brug af styringssystemet, eller omkring vejledningerne i vejledningen, skal du kontakte din autoriserede forhandler eller teknisk support.
- Operatøren skal til alle tider være opmærksom på eventuelle forhindringer i køretøjets bane. Styringssystemet kan ikke identificere eller undgå forhindringer.
- Operatøren skal forblive i operatørens sæde inden i køretøjet mens styringssystemet er aktiveret.
- Brug kun styringssystemet i en åben mark. Systemerne skal slukkes når køretøjet befinder sig på en kørebane, uanset hvilken slags.

Ansvarligheds erklæring Novariant B.V. kan ikke holdes ansvarlig eller forpligtet på nogen måde for nogen form for skader og/eller ulykker, fra fejlfunktion af den maskine, som systemet er installeret på, eller fejlfunktion af maskinens komponenter, maskinens attributter (f.eks. en anhænger), tredjeparts-forstyrrelser eller operatørhandling udenfor de tilsigtede, som beskrevet af Novariant B.V.

COPYRIGHT MEDDELELSE Ag Leader Technology har copyrights (©2014) til indholdet af denne udgivelse og driftsprogrammet for INTEGRA og VERSA systemerne. Der må ikke laves kopier uden der først indhentes tilladelse fra Ag Leader Technology.

Deutsch (German)

OnTrac3 System

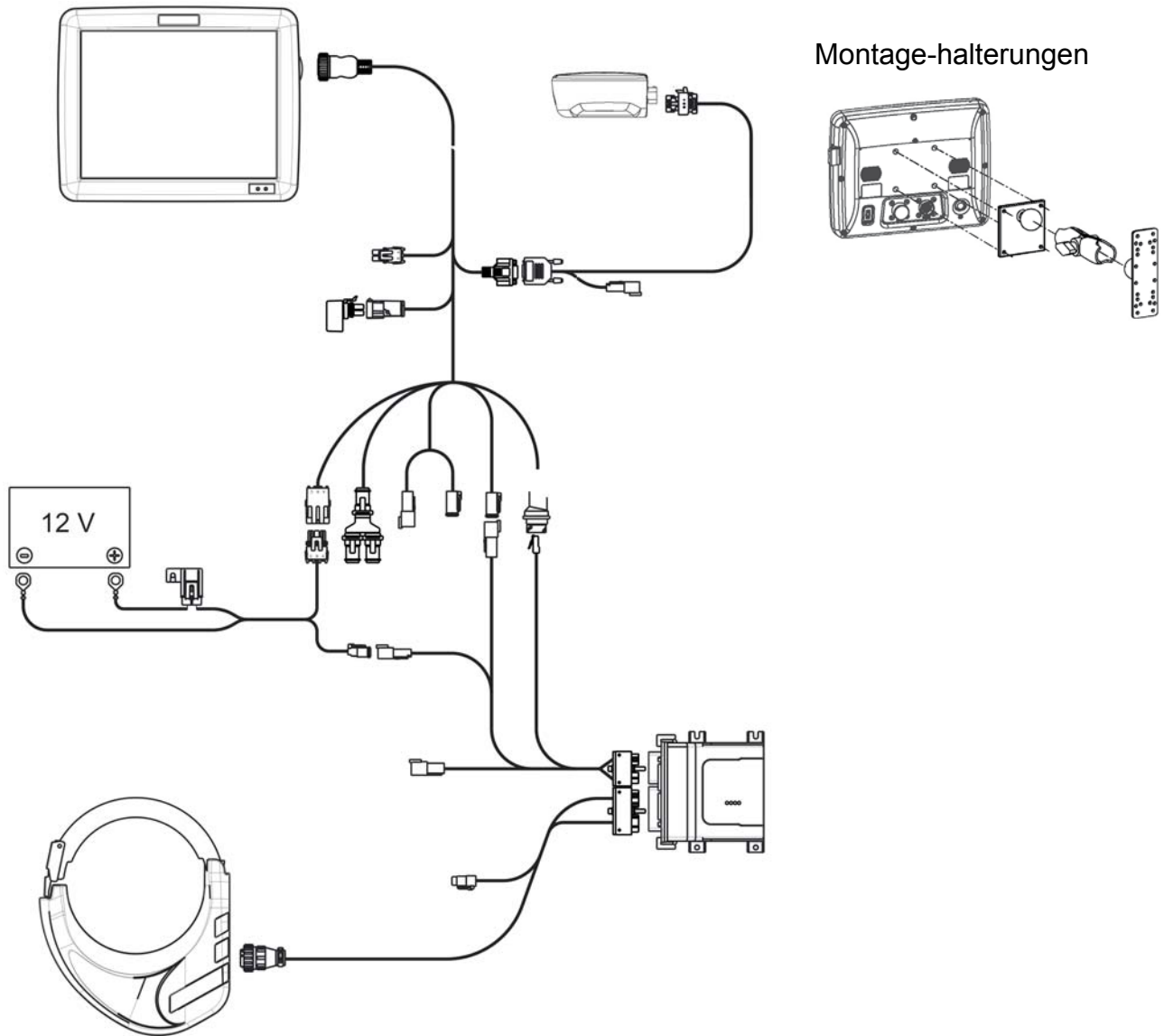

Sicherungstyp

Flachsicherung (ATO/ATC)

5 A

15 A

Betriebsspannung

9 – 16 V Gleichspannung

Maximalstrom

Ag Leader Integra4,0 A

Versa2,5 A

Technische Daten

Achten Sie darauf, dass die nachstehenden Spezifikationen nicht überschritten werden:

•Lagerungstemperatur:

-20 bis 80 °C

•Betriebstemperatur:

-10 bis 70 °C

•Schutzart: IP64

•Keine Schutz Erde erforderlich

•150 V-Minimalisolierung bei externen Schaltungen nutzen

Sicherheitshinweis: Lesen Sie Sicherheitshinweise und Bedienungsanleitungen gründlich durch, halten Sie sich an sämtliche Anweisungen.

Lenkungssystem/Steuerungssystem bezieht sich auf das OnTrac2 GPS Assisted Steering System, das OnTrac3 GPS Assisted Steering System, das ParaDyme-System und/oder das GeoSteer-System.

- Das Lenkungssystem darf nur von Personen bedient werden, die zur Führung des entsprechenden Fahrzeugs berechtigt sind.
- Das Sicherheitstempolimit des Geländes, auf dem das Fahrzeug eingesetzt wird, darf nicht überschritten werden.
- Anwender des Lenkungssystems müssen sich bei der Bedienung jederzeit in vollem Umfang ihrer Handlungen bewusst sein.
- Wenden Sie bei der Installation des Lenkungssystems keinerlei Gewalt an – dies kann zu Beschädigungen der Komponenten führen.
- Halten Sie sich grundsätzlich an die Anweisungen der Installations-, Betriebs- und Wartungsunterlagen.
- Das Lenkungssystem sollte ausschließlich von geschultem Personal bedient werden.
- Überprüfen Sie grundsätzlich den Lieferumfang der gelieferten Komponenten; überzeugen Sie sich davon, dass die richtigen Komponenten vorhanden sind. Verwenden Sie ausschließlich Originalkomponenten; versuchen Sie niemals, Originalkomponenten durch andere Komponenten zu ersetzen.
- Bei Fragen zur sicheren Bedienung des Lenkungssystems und bei Fragen zu den Anweisungen der Bedienungsanleitungen wenden Sie sich bitte unverzüglich an Ihren autorisierten Händler oder an den technischen Kundendienst.
- Setzen Sie bei der Installation des Lenkungssystems grundsätzlich die richtigen, passenden Werkzeuge ein.
- Damit es nicht zu Verletzungen kommt, führen Sie die Installation des Lenkungssystems mit Sorgfalt und Vorsicht aus.
- Verwenden Sie das Lenkungssystem nicht bei unsicheren Wetterbedingungen.
- Verwenden Sie das Lenkungssystem nicht in unsicherem Gelände.
- Das Lenkungssystem darf nur von Personen bedient werden, die entsprechend ausgebildet wurden, über die nötige Erfahrung verfügen und zur Nutzung oder Bedienung autorisiert wurden.
- Vor Beginn des Arbeitseinsatzes muss sich der Bediener in ausreichendem Umfang über die sichere Bedienung des Lenkungssystems informieren.
- Bei der Installation des Lenkungssystems müssen sämtliche Sicherheitsvorkehrungen voll und ganz verstanden und beachtet werden. Lose, beschädigte oder unvollständige Teile dürfen nicht eingesetzt werden
- Überprüfen Sie vor dem Einsatz des Lenkungssystems sämtliche Funktionen und Eigenschaften auf einwandfreie Funktion. Falls auch nur der geringste Zweifel bestehen sollte, gehen Sie kein Risiko ein – wenden Sie sich grundsätzlich an Ihren autorisierten Händler oder den technischen Kundendienst.
- Überprüfen Sie sämtliche Funktionen des Bedienerpräsenzschalters vor dem Einsatz des Lenkungssystems auf einwandfreie Funktion.
- Das Lenkungssystem muss grundsätzlich mit den vorgegebenen Schritten ein- und ausgeschaltet werden.
- Bei anormalen Fahrzeug- oder Systemfunktionen – beispielsweise bei übermäßigen Vibrationen oder starker Geräuschentwicklung – stoppen Sie das Fahrzeug sofort, schalten das Lenkungssystem AUS und wenden sich an Ihren autorisierten Händler oder an den technischen Kundendienst.
- Vor Wartung und Reinigung des Lenkungssystems muss das System vollständig ABGESCHALTET und stromlos gemacht werden.
- Anwender des Lenkungssystems müssen sich mit sämtlichen Sicherheitshinweisen gründlich vertraut machen, damit bei Notfällen entsprechend richtig reagiert werden kann.
- Wartungsarbeiten und Reparaturen des Lenkungssystems müssen grundsätzlich durch den autorisierten Händler ausgeführt werden.
- Bei Reparaturen und Instandsetzungen von Komponenten des Lenkungssystems dürfen nur Originalteile verwendet werden.
- Bei sämtlichen Arbeiten am Lenkungssystem ist das Tragen geeigneter persönlicher Schutzausrüstung zwingend vorgeschrieben.
- Bei der Reinigung des Lenkungssystems dürfen nur zugelassene/empfohlene Reinigungs- und sonstige Hilfsmittel eingesetzt werden.
- Falls sich beim Einsatz des Lenkungssystems unsichere Situation ergeben sollten, muss dies Ihrem autorisierten Händler oder dem technischen Kundendienst möglichst unverzüglich mitgeteilt werden.
- Auf dem Lenkungssystem sowie in dessen Nähe dürfen keine Gegenstände abgestellt werden.
- Bei Installation, Kalibrierung und Abstimmung des Lenkungssystems können sich die Räder des Fahrzeugs nach links und rechts bewegen. Achten Sie darauf, dass sich keine Personen oder Hindernisse in der Nähe der Räder befinden, bevor Sie fortfahren.
- Bringen Sie Fahrzeugsitz und Lenkrad in die gewohnten Betriebspositionen, vergewissern Sie sich, dass die OnTrac2 Mechanical Drive Unit (MDU) keine Bedienelemente berührt.
- Bei jedem Einschalten des Systems muss der Hinweis zur Haftung zum automatischen Steuerungssystem vom Bediener gelesen und bestätigt werden.
- Bei Fragen zur sicheren Bedienung des Lenkungssystems und bei Fragen zu den Bedienungshinweisen wenden Sie sich bitte an Ihren autorisierten Händler oder an den technischen Kundendienst.
- Auf Hindernisse in Fahrtrichtung des Fahrzeugs ist grundsätzlich zu achten. Hindernisse können vom Lenkungssystem weder erkannt noch umfahren werden.
- Beim Einsatz des Lenkungssystems darf der Bediener den Fahrersitz nicht verlassen.
- Nutzen Sie das Lenkungssystem ausschließlich auf dem offenen Feld. Die Systeme müssen ABGESCHALTET werden, sobald das Fahrzeug auf Straßen oder Wegen gleich welcher Art eingesetzt wird.

Haftungsausschluss Novariant B. V. haftet nicht für jegliche Schäden oder Unfälle, die durch Fehlfunktionen des Trägerfahrzeugs, Zusatzeinrichtungen (z. B. Anhänger), durch Eingriffe Dritter oder nicht von Novariant B. V. vorgeschriebene Handlungen des Bedieners verursacht werden.

Hinweise zum Urheberrecht Ag Leader Technology besitzt das Urheberrecht (© 2014) an den Inhalten dieser Publikation und an den Steuerprogrammen für INTEGRA- und VERSA-Systeme. Jegliche Vervielfältigungen ohne vorherige Zustimmung der Ag Leader Technology sind untersagt.

Español (Spanish_Argentina)

Sistema OnTrac3

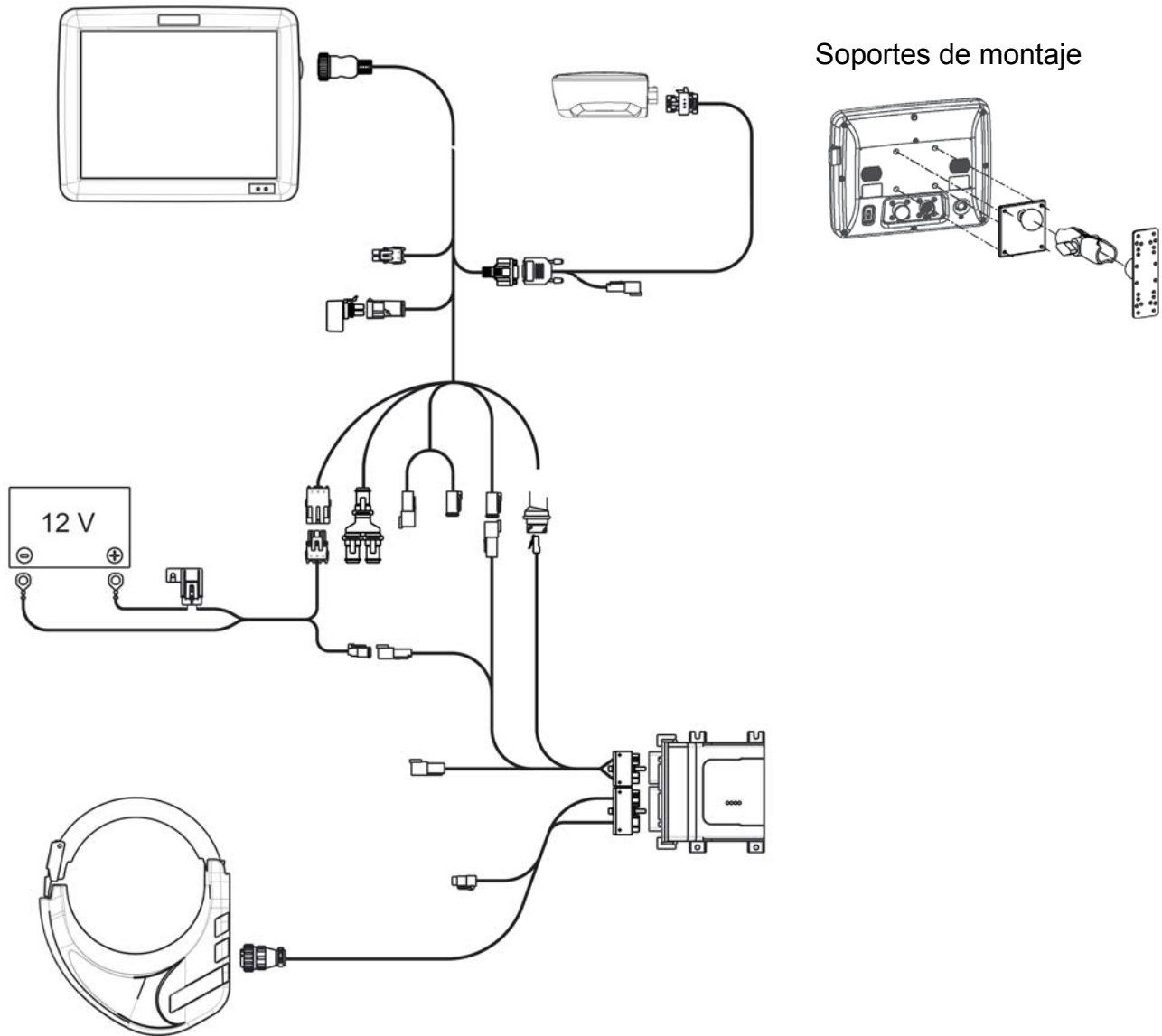

Tipo de fusible

Estilo lámina (ATO/ATC)

Capacidad nominal 5 A

Capacidad nominal 15 A

Voltaje de operación

9-16 V CC

Capacidad nominal máxima de corriente

Ag Leader Integra4,0 A

Versa2,5 A

Especificaciones técnicas

No exceda las siguientes especificaciones:

- Temperatura de almacenamiento:
Entre -4° y +176°F (entre -20° y +80°C)
- Temperatura de funcionamiento:
Entre 14° y +156°F (entre -10° y +70°C)
- Especificación de protección ambiental: IP64
- No se requiere tierra de protección
- Use una especificación de aislamiento mínima de 150 V para circuitos externos

Aviso de seguridad: Lea bien las instrucciones de seguridad y los Manuales del usuario y siga las instrucciones.

El sistema de mando se refiere al Sistema de mando asistido por GPS OnTrac2 y/o el Sistema de mando asistido por GPS OnTrac3 y/o el Sistema Paradyne y/o el Sistema GeoSteer.

- Solo un operador plenamente autorizado para manejar el vehículo puede usar el Sistema de mando asistido OnTrac2 GPS y/o el sistema ParaDyme.
- El operador no debe exceder el límite seguro de velocidad para el terreno en el que opera el vehículo.
- El operador siempre debe tener presente sus acciones al operar el Sistema de mando asistido OnTrac2 GPS y/o el sistema ParaDyme.
- Al instalar el Sistema de mando asistido OnTrac2 GPS y/o el sistema ParaDyme, no fuerce los componentes ya que esto puede resultar en daños a los componentes.
- Siga siempre las instrucciones de los manuales de instalación, operación y mantenimiento.
- Únicamente personal capacitado debe instalar el Sistema de mando asistido OnTrac2 GPS y/o el sistema ParaDyme.
- Haga siempre un inventario de los componentes entregados para garantizar que todos los componentes correctos estén presentes. Nunca use componentes de repuesto. Use solo componentes originales.
- Si tiene preguntas con respecto a la operación segura del Sistema de mando asistido OnTrac2 GPS y/o el sistema ParaDyme, o de las instrucciones de los manuales, comuníquese de inmediato con su distribuidor autorizado o con Soporte técnico.
- Use siempre las herramientas correctas para instalar el Sistema de mando asistido OnTrac2 GPS y/o el sistema ParaDyme.
- Para prevenir lesiones, tenga precaución al instalar el Sistema de mando asistido OnTrac2 GPS y/o el sistema ParaDyme.
- No use u opere el Sistema de mando asistido OnTrac2 GPS y/o el sistema ParaDyme en condiciones climáticas no seguras.
- No use u opere el Sistema de mando asistido OnTrac2 GPS y/o el sistema ParaDyme en terrenos no seguros.
- Solo un operador capacitado, experimentado o autorizado puede usar u operar el Sistema de mando asistido OnTrac2 GPS y/o el sistema ParaDyme.
- Antes de usar el Sistema de mando asistido OnTrac2 GPS y/o el sistema ParaDyme, el operador debe tener suficientes conocimientos sobre cómo operar los sistemas de manera segura.
- Al instalar el Sistema de mando asistido OnTrac2 GPS y/o el sistema ParaDyme se deben comprender claramente todas las precauciones de seguridad. Si hay alguna pieza que esté floja, deteriorada o faltante, no se debe usar.
- Antes de usar el Sistema de mando asistido OnTrac2 GPS y/o el sistema ParaDyme, verifique que se revisen y controlen todas las funciones para garantizar que trabajen correctamente. En caso de duda, no asuma riesgos, comuníquese siempre con su distribuidor autorizado o con Soporte técnico.
- Antes de operar el Sistema OnTrac2 y/o el sistema ParaDyme, verifique todas las funciones del Interruptor de presencia del operador para garantizar que funciona correctamente.
- Para encender o apagar el Sistema OnTrac2 y/o el sistema ParaDyme, se deben seguir los procedimientos correctos prescritos.
- Si algún vehículo o función del sistema opera en forma anormal, por ejemplo, si ocurren vibraciones excesivas o ruido, detenga el vehículo de inmediato, apague el Sistema de mando asistido OnTrac2 y/o el sistema ParaDyme y comuníquese con su distribuidor autorizado o con Soporte técnico.
- Al hacerle mantenimiento o limpieza al Sistema OnTrac2 y/o al sistema ParaDyme, el sistema debe estar completamente apagado y libre de corriente eléctrica.
- El operador del Sistema de mando asistido OnTrac2 GPS conjuntamente con el sistema ParaDyme debe leer y comprender todas las instrucciones de seguridad para poder reaccionar en caso de emergencia.
- El mantenimiento o reparación al Sistema de mando asistido OnTrac2 GPS y/o al sistema ParaDyme debe siempre ser realizado por el distribuidor autorizado.
- Durante la reparación o el reemplazo de los componentes del Sistema de mando asistido OnTrac2 GPS y/o el sistema ParaDyme sólo se deben usar componentes originales.
- El operador o el personal de mantenimiento deben siempre llevar puesto equipos de protección personal al trabajar con el Sistema de mando asistido OnTrac2 GPS y/o el sistema ParaDyme.
- El personal de mantenimiento debe siempre usar los materiales de limpieza y accesorios recomendados al limpiar el Sistema de mando asistido OnTrac2 GPS y/o el sistema ParaDyme.
- Las condiciones o situaciones no seguras con el Sistema de mando asistido OnTrac2 GPS y/o el sistema ParaDyme deben ser notificadas a su distribuidor autorizado o a Soporte técnico.
- No se pueden colocar objetos en el Sistema de mando asistido OnTrac2 GPS y/o el sistema ParaDyme o en el área de tales sistemas.
- Durante la instalación, calibración y sintonización del Sistema de mando asistido OnTrac2 GPS y/o el sistema ParaDyme, las ruedas del vehículo pueden girar a la izquierda y derecha. Asegúrese de que no haya personas ni obstáculos en el área de las ruedas antes de proceder.
- Coloque el asiento del vehículo y el volante de mando en posición de operación normal y compruebe que la Unidad de accionamiento mecánico (MDU) OnTrac2 no interfiera con ninguno de los controles.
- El operador debe leer y aceptar el Aviso de responsabilidad de mando automático cada vez que se enciende el sistema.
- Si tiene preguntas con respecto a la operación segura del Sistema de mando asistido OnTrac2 GPS y/o el sistema ParaDyme, o de las instrucciones de operación, comuníquese de inmediato con su distribuidor autorizado o con Soporte técnico.
- El operador debe mantenerse alerta en caso de obstáculos en la trayectoria del vehículo. El Sistema de mando asistido OnTrac2 GPS y/o el sistema ParaDyme no pueden identificar o evitar obstáculos.
- El operador debe mantenerse en el asiento del operador del vehículo mientras se conecta el Sistema de mando asistido OnTrac2 GPS y/o el sistema ParaDyme.
- Use el Sistema de mando asistido OnTrac2 GPS y/o el sistema ParaDyme solamente en campo abierto. Los sistemas deben estar apagados mientras el vehículo se encuentra en algún tipo de carretera.

Aviso de responsabilidad: Novariant B.V. de ninguna manera se hace responsable por cualesquiera daños y/o accidentes que ocurran por el funcionamiento indebido de la máquina en el que el sistema se encuentre instalado, por el funcionamiento indebido de los componentes de la máquina, características de la máquina (por ej. remolques), interferencias de terceros o actos del operador fuera del uso previsto prescrito por Novariant B.V.

AVISO DE DERECHOS DE AUTOR: Ag Leader Technology tiene derechos de autor (©2011) sobre el contenido de esta Guía de referencia y sobre el programa de operación de los sistemas INTEGRA y VERSA. No pueden hacerse reproducciones sin el consentimiento previo de Ag Leader Technology.

Français (French)

Système OnTrac3

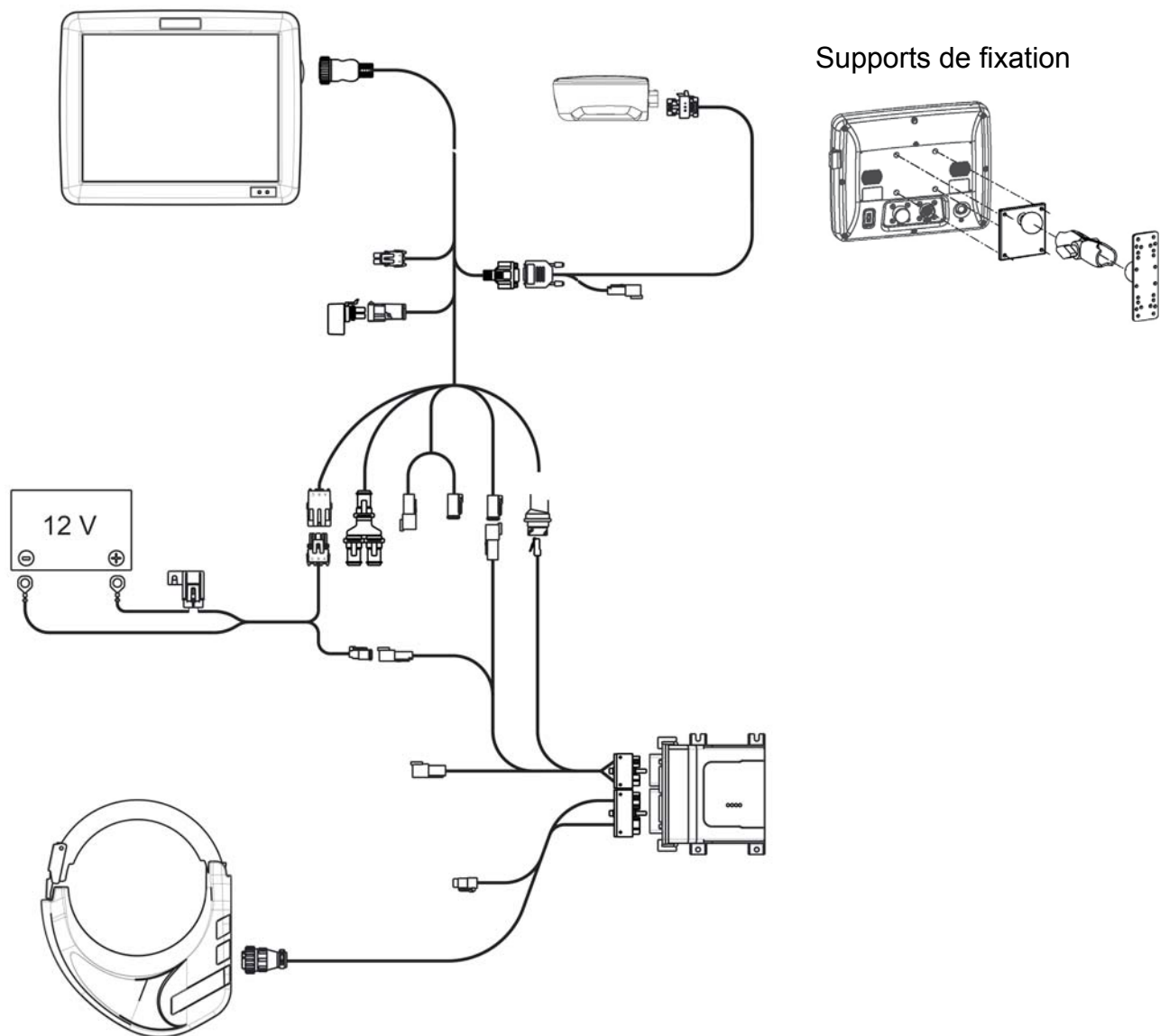

Type de fusible

À lame (ATO/ATC)

5 A

15 A

Tension de service

9 à 16 V c.c.

Courant nominal max.

Ag Leader Integra 4,0 A

Versa 2,5 A

Respecter les caractéristiques suivantes :

- Température de stockage :
-20 à +80 °C (-4 à +176 °F)
- Température de service :
-10 à +70 °C (14 à +156 °F)
- Indice de protection : IP64
- Aucune mise à la terre requise
- Les circuits externes doivent présenter une caractéristique d'isolement minimale de 150 V

Avis de sécurité* : Lisez soigneusement ces consignes de sécurité ainsi que le Manuel d'utilisation et respectez les instructions.

Seul un opérateur possédant toutes les capacités à conduire le véhicule peut se servir du système de pilotage assisté par GPS OnTrac2 ou du système ParaDyme.

- L'opérateur ne doit pas dépasser la limite de vitesse de sécurité définie pour le véhicule en fonction du terrain.
- L'opérateur doit toujours être conscient de la portée de ses actes au cours de l'utilisation du système de pilotage assisté par GPS OnTrac2 ou du système ParaDyme.
- Ne forcez sur aucun composant au cours de l'installation du système de pilotage assisté par GPS OnTrac2 ou du système ParaDyme, les composants concernés pourraient être endommagés.
- Suivez toujours les instructions contenues dans les manuels d'installation, d'exploitation et d'entretien.
- Seul du personnel qualifié doit installer le système de pilotage assisté par GPS OnTrac2 ou le système ParaDyme.
- Répertoirez toujours les composants livrés pour vous assurer qu'aucun d'entre eux ne manque. N'utilisez jamais de composants de substitution. Utilisez uniquement des composants d'origine.
- En cas de question concernant l'utilisation dans des conditions de sécurité optimales du système de pilotage assisté par GPS OnTrac2 ou du système ParaDyme ainsi que sur les instructions du mode d'emploi, n'hésitez pas à consulter votre vendeur agréé ou le support technique.
- Utilisez toujours les outils appropriés pour installer le système de pilotage assisté par GPS OnTrac2 ou le système ParaDyme.
- Pour éviter tout dommage corporel, soyez prudent au cours de l'installation du système de pilotage assisté par GPS OnTrac2 ou du système ParaDyme.
- N'utilisez ou n'actionnez pas le système de pilotage assisté par GPS OnTrac2 ou le système ParaDyme lors de conditions climatiques dangereuses.
- N'utilisez ou n'actionnez pas le système de pilotage assisté par GPS OnTrac2 ou le système ParaDyme sur un terrain dangereux.
- Seul un opérateur qualifié, expérimenté et agréé peut se servir du système de pilotage assisté par GPS OnTrac2 ou du système ParaDyme.
- Avant toute utilisation du système de pilotage assisté par GPS OnTrac2 ou du système ParaDyme, l'opérateur doit posséder une connaissance suffisante de l'utilisation en toute sécurité de ces systèmes.
- Au cours de l'installation du système de pilotage assisté par GPS OnTrac2 ou du système ParaDyme, toutes les consignes de sécurité doivent être parfaitement comprises. Les pièces desserrées, manquantes ou endommagées ne doivent pas être utilisées.
- Avant d'utiliser le système de pilotage assisté par GPS OnTrac2 ou le système ParaDyme, le fonctionnement de toutes les fonctions doit être vérifié. En cas de doute, ne prenez aucun risque et consultez votre vendeur agréé ou le support technique.
- Avant d'utiliser les systèmes OnTrac2 ou ParaDyme, vérifiez toutes les fonctions du commutateur de présence, tout doit fonctionner correctement.
- Les opérations de mise sous tension ou d'arrêt du système OnTrac2 ou ParaDyme doivent être effectuées en respectant les procédures appropriées.
- Si toute fonction du véhicule ou du système s'avère être anormale, par exemple des vibrations ou des bruits importants, arrêtez immédiatement le véhicule, mettez le système de pilotage assisté par GPS OnTrac2 ou le système ParaDyme hors tension et prenez contact avec votre vendeur agréé ou le support technique.
- Au cours des opérations d'entretien ou de nettoyage des systèmes OnTrac2 ou ParaDyme, ces derniers doivent être hors tension et exempt de tout courant électrique.
- L'opérateur du système de pilotage assisté par GPS OnTrac2 en combinaison avec le système ParaDyme doit lire et comprendre toutes les consignes de sécurité pour pouvoir réagir promptement en cas d'urgence.
- Le vendeur agréé doit toujours entreprendre les opérations d'entretien et de réparation du système de pilotage assisté par GPS OnTrac2 ou du système ParaDyme.
- Seuls des composants d'origine doivent être utilisés au cours de la réparation ou du remplacement du système de pilotage assisté par GPS OnTrac2 ou du système ParaDyme.
- Au cours de travaux sur le système de pilotage assisté par GPS OnTrac2 ou le système ParaDyme, l'opérateur ou le personnel d'entretien doit toujours porter l'équipement de protection individuel approprié.
- Le personnel d'entretien doit toujours utiliser les produits et accessoires de nettoyage recommandés pour le nettoyage du système de pilotage assisté par GPS OnTrac2 ou du système ParaDyme.
- Les conditions ou situations dangereuses relatives au système de pilotage assisté par GPS OnTrac2 ou au système ParaDyme doivent être reportées à votre vendeur agréé ou au support technique.
- Aucun objet ne doit être placé sur ou à proximité du système de pilotage assisté par GPS OnTrac2 ou du système ParaDyme.
- Au cours de l'installation, de la calibration et du réglage du système de pilotage assisté par GPS OnTrac2 ou du système ParaDyme, les roues du véhicule vont tourner à gauche et à droite. Veillez à ce que les personnes et obstacles soient tenus éloignés des roues avant de procéder à ces opérations.
- Placez le siège du véhicule et le volant en position normale d'utilisation et vérifiez que l'unité d'entraînement mécanique Mechanical Drive Unit (MDU) OnTrac2 n'interfère pas avec les commandes.
- L'opérateur doit lire et valider l'Avis de responsabilité du pilotage automatique à chaque fois que le système est mis sous tension.
- En cas de question concernant l'utilisation dans des conditions de sécurité optimales du système de pilotage assisté par GPS OnTrac2 ou du système ParaDyme ainsi que sur les instructions d'utilisation, n'hésitez pas à consulter votre vendeur agréé ou le support technique.
- L'opérateur doit rester attentif aux obstacles survenant sur le chemin du véhicule. Le système de pilotage assisté par GPS OnTrac2 ou le système ParaDyme ne peut détecter ou éviter les obstacles.
- L'opérateur doit toujours rester dans le siège du conducteur, dans le véhicule, lorsque le système de pilotage assisté par GPS OnTrac2 ou le système ParaDyme est activé.
- Utilisez uniquement le système de pilotage assisté par GPS OnTrac2 ou le système ParaDyme en plein champ. Le système doit être mis hors tension lorsque le véhicule se trouve sur une chaussée.

* L'avis de sécurité du système OnTrac2 est également valable pour OnTrac3.

Avis de responsabilité Novariant B.V. ne saurait être tenu responsable, de quelle que façon que ce soit, pour tous dégâts ou accidents pouvant survenir à la suite d'un dysfonctionnement de la machine sur laquelle le dispositif est installé, une défaillance des composants de la machine, des attributs de la machine (remorques, ...), des interférences de systèmes tiers ou d'actions de l'opérateur non conformes à l'usage normal indiqué par Novariant B.V.

DROITS D'AUTEUR Ag Leader Technology a protégé les droits par copyright (©2011) du contenu de la présente publication ainsi que du programme des systèmes INTEGRA et VERSA. Aucune reproduction du document n'est possible sans accord préalable d'Ag Leader Technology.

Italiano (Italian)

Sistema OnTrac3

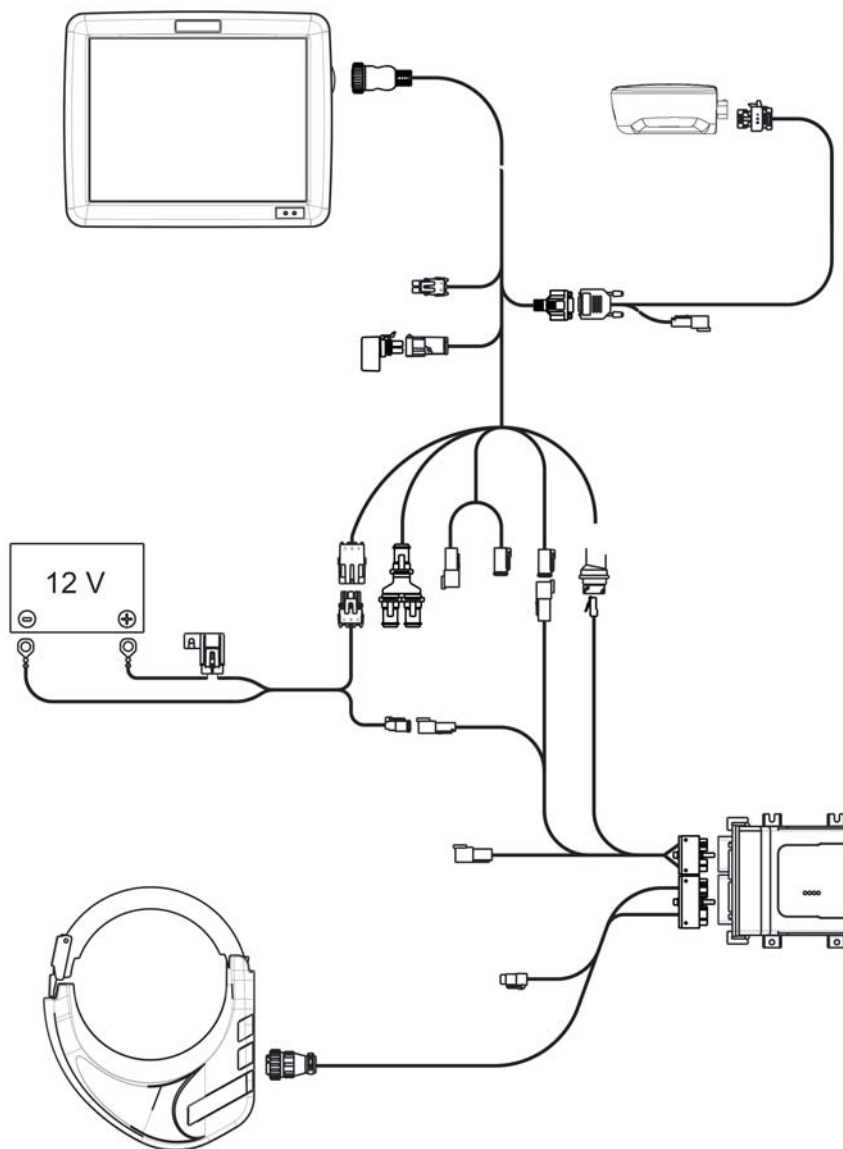

Montaggio

StaffeMontage-steun

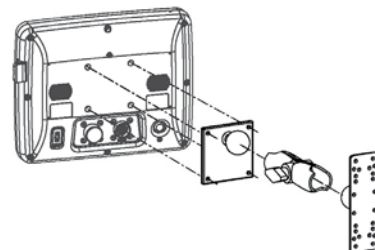

<p>Tipo di fusibile Tipo a lama (ATO/ATC) Livello 5 A Livello 15 A Tensione di funzionamento 9 –16 V CC Corrente massima nominale: Ag Leader Integra4,0 A Versa2,5 A</p>	<p>Specifiche tecniche</p> <p>Non superare le seguenti specifiche:</p> <ul style="list-style-type: none">• Temperatura di conservazione: da -4° a +176°F (da -20° a +80°C)• Temperatura di esercizio: da 14° a +156°F (da -10° a +70°C)• Valutazione indice di protezione: IP64• Non è necessaria la protezione con messa a terra• Per i circuiti esterni utilizzare l'isolamento 150V circuits
--	---

Avviso di sicurezza: Leggere attentamente le istruzioni sulla sicurezza e il manuale di istruzioni per l'utente e osservare le indicazioni riportate.

Il sistema sterzante fa riferimento al sistema di servosterzo OnTrac2 GPS e/o il sistema di servosterzo OnTrac3 e/o il sistema ParaDyme e/o il sistema GeoSteer.

- Il sistema sterzante deve essere utilizzato esclusivamente da operatori autorizzati alla guida del veicolo.
 - L'operatore non deve superare il limite di velocità di sicurezza indicato per il terreno operativo.
 - Durante l'utilizzo del sistema sterzante, l'operatore deve essere sempre consapevole delle proprie azioni.
 - Durante l'installazione del sistema sterzante, prestare attenzione a non forzare i componenti, in quanto potrebbero danneggiarsi.
 - Osservare sempre le istruzioni riportate nei manuali di installazione, funzionamento e manutenzione.
 - L'installazione del sistema sterzante deve essere effettuata esclusivamente da personale esperto.
 - Effettuare sempre l'inventario dei componenti forniti, in modo da garantire che tutti i componenti corretti siano disponibili. Non utilizzare mai componenti sostitutivi. Utilizzare esclusivamente componenti originali.
 - Per eventuali domande inerenti il funzionamento sicuro del sistema sterzante o per le istruzioni riportate nei manuali, non esitare a contattare il concessionario autorizzato locale o il supporto tecnico.
 - Per eseguire l'installazione del sistema sterzante utilizzare sempre gli strumenti corretti.
 - Per evitare eventuali lesioni personali, prestare sempre la massima attenzione durante l'installazione del sistema sterzante.
 - Non utilizzare o attivare il sistema sterzante se le condizioni atmosferiche sono rischiose.
 - Non utilizzare o attivare il sistema sterzante se il terreno è accidentato.
 - Il sistema sterzante deve essere utilizzato esclusivamente da operatori autorizzati.
 - Prima di avviare le attività, l'operatore deve aver acquisito sufficiente familiarità con la modalità di funzionamento sicura del sistema sterzante.
-
- Durante l'installazione del sistema sterzante, è necessario aver compreso interamente tutte le misure sulla sicurezza. Se alcuni componenti sono allentati, mancanti o danneggiati, non procedere con l'utilizzo.
 - Prima di utilizzare il sistema sterzante, è necessario verificare tutte le funzioni, in modo da assicurarne il corretto funzionamento. In caso di dubbi, non esporsi mai a rischi e contattare sempre il proprio concessionario locale o il supporto tecnico.
 - Prima di avviare il sistema sterzante, verificare che tutte le opzioni dell'interruttore presenza operatore siano funzionanti.
 - L'attivazione e la disattivazione del sistema sterzante devono essere effettuate seguendo le procedure indicate.
 - In caso di funzionamento anomalo del veicolo o del sistema, ad esempio in presenza di rumori o vibrazioni eccessive, arrestare immediatamente il veicolo, disattivare il sistema sterzante e contattare il proprio concessionario locale o il supporto tecnico.
 - Durante gli interventi di manutenzione o di pulizia del sistema sterzante, è necessario che questo sia completamente disattivato e privo di alimentazione elettrica.
 - L'operatore del sistema sterzante deve aver letto e compreso interamente le istruzioni sulla sicurezza, in modo da poter intervenire in caso di emergenza.
 - Gli interventi di manutenzione o di riparazione sul sistema sterzante devono essere eseguiti sempre dal concessionario autorizzato.
 - Per la riparazione o la sostituzione dei componenti sul sistema sterzante, utilizzare esclusivamente componenti originali.
 - Per eseguire le operazioni sul sistema sterzante, l'operatore o il personale per la manutenzione devono sempre indossare un'attrezzatura di protezione.
 - Durante l'intervento di pulizia del sistema sterzante, il personale di manutenzione deve utilizzare sempre il materiale e gli accessori per la pulizia consigliati.
 - Eventuali condizioni o situazioni rischiose relative al sistema sterzante devono essere comunicate al proprio concessionario autorizzato o al supporto tecnico.
 - Non posizionare oggetti al di sopra o all'interno dell'area del sistema sterzante.
 - Durante l'installazione, la calibrazione e la messa a punto del sistema sterzante, le ruote del veicolo potrebbero girare verso destra o sinistra. Prima di procedere con l'operazione, assicurarsi che nell'area circostante non vi siano persone od ostacoli.
 - Collocare il sedile e il volante del veicolo nella posizione operativa normale e verificare che l'unità di comando meccanico (MDU) non interferisca con i comandi.
 - Tutte le volte che il sistema viene attivato, l'operatore deve leggere e comprendere interamente l'Avviso di responsabilità dello sterzo automatico.
 - Per eventuali domande inerenti il funzionamento sicuro del sistema sterzante o per le istruzioni operative, non esitare a contattare il concessionario autorizzato locale o il supporto tecnico.
 - L'operatore deve prestare attenzione agli ostacoli lungo il percorso del veicolo. Il sistema sterzante non è in grado di individuare o evitare gli ostacoli.
 - Quando il sistema sterzante è innescato, l'operatore deve rimanere nella propria postazione sul veicolo.
 - Utilizzare il sistema sterzante solamente in campo aperto. Disattivare i sistemi quando il veicolo si trova su qualsiasi tipo di strada.

Avviso di responsabilità: Novariant B.V. non sarà in nessun caso ritenuta responsabile per eventuali danni e/o incidenti causati dal malfunzionamento della macchina su cui è stato installato il sistema, dal malfunzionamento dei componenti della macchina, dalle parti aggiuntive della macchina (ad es. i rimorchi), dalle interferenze di terze parti o da azioni eseguite dall'operatore che non rientrino nell'uso convenuto, così come indicato da Novariant B.V.

DICHIARAZIONE DI COPYRIGHT Ag Leader Technology ha tutelato con copyright (©2014) il contenuto della presente pubblicazione e il programma operativo per i sistemi INTEGRA e VERSA. È vietata la riproduzione senza previo consenso da parte di Ag Leader Technology.

Magyar (Hungarian)

OnTrac3 rendszer

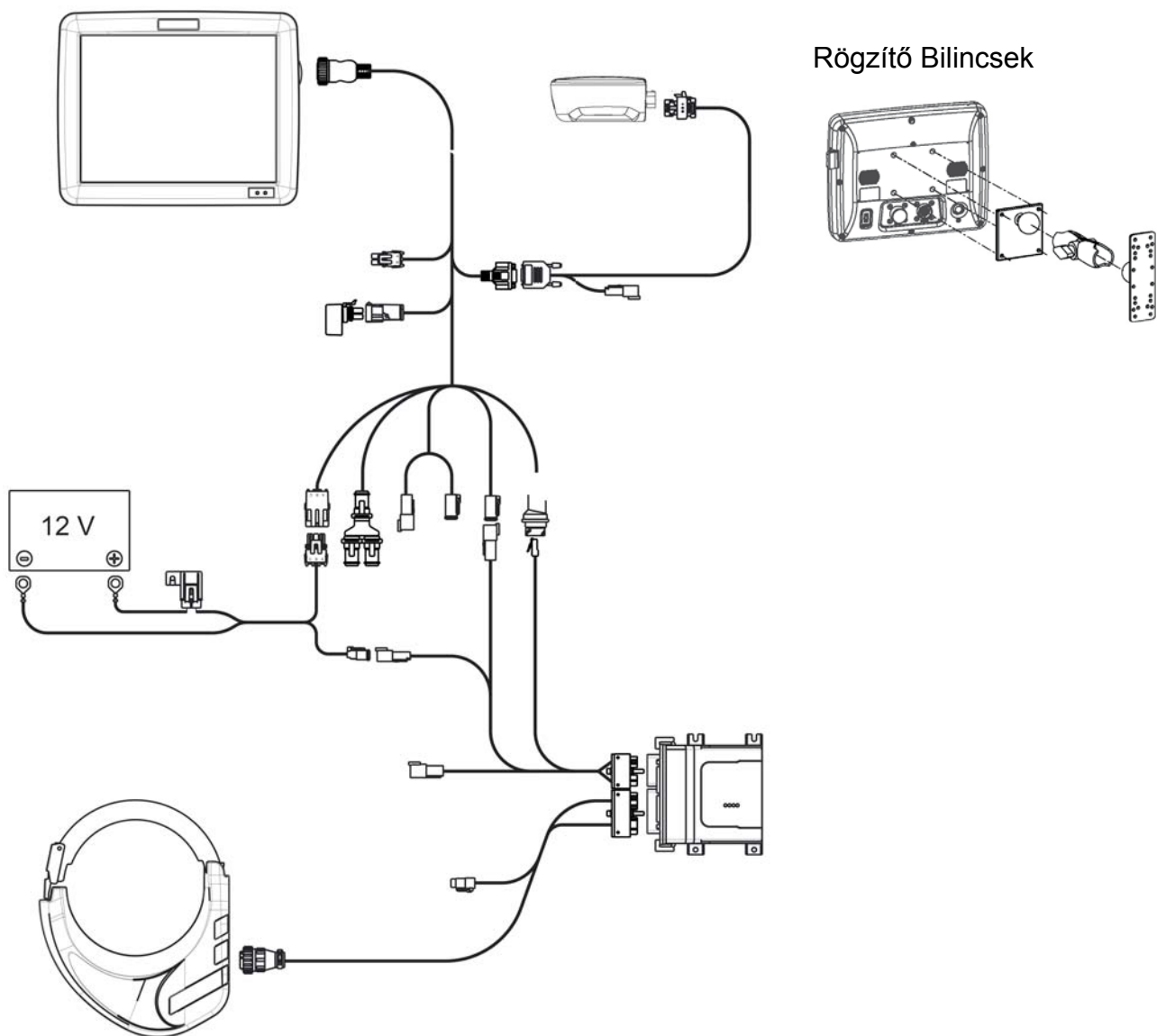

Biztosíték típusa

Késes (ATO/ATC)

5 A névleges

15 A névleges

Üzemi feszültség

9 - 16 V DC

Max. névleges áram

Ag Leader Integra 4,0 A

Versa 2,5 A

Műszaki adatok

Ne lépje túl az alábbi feltételeket:

• Tárolási hőmérséklet:

-4° és +176°F (-20° és +80°C) között

• Üzemi hőmérséklet:

14° és +156°F (-10° és +70°C) között

• Környezetvédelmi besorolás: IP64

• Nincs szükség védőföldre

• A külső áramkörök esetében legalább 150 voltos szigetelési szilárdság szükséges

Biztonsági figyelmeztetés: Alaposan olvassa át ezeket a biztonsági utasításokat és a Felhasználói kézikönyveket, és tartsa be az utasításokat.

A kormányzási rendszer (robotpilóta) az OnTrac2 GPS Assisted Steering System (GPS-támogatású kormányzási rendszert) és/vagy az OnTrac3 GPS Assisted Steering System (GPS-támogatású kormányzási rendszert) és/vagy a ParaDyme rendszert és/vagy a GeoSteer rendszert jelenti.

- Csak a jármű vezetésére felhatalmazott személy használhatja a kormányzási rendszert.
- A kezelő nem lépheti túl a munkavégzés terepén megengedett biztonságos sebességhatárt.
- A kezelőnek mindig tudatában kell lennie a kormányzási rendszer használata során megtett intézkedéseinek.
- A kormányzási rendszer telepítésekor ne erőltesse az alkatrészeket, mert ez az alkatrészek meghibásodásához vezethet.
- Mindig tartsa be a telepítési, üzemeltetési és karbantartási kézikönyvekben levő utasításokat.
- Csak szakképzett személy telepítse a kormányzási rendszert.
- Mindig vegye számba a leszállított alkatrészeket, hogy a megfelelő elemek állnak-e rendelkezésre. Soha ne használjon utángyártott alkatrészeket. Csak eredeti alkatrészeket használjon.
- Ha kérdések merülnek fel a kormányzási rendszer biztonságos használatával vagy a kézikönyvek utasításaival kapcsolatban, akkor azonnal keresse a hivatalos forgalmazót vagy a műszaki ügyfélszolgálatot.
- Mindig a megfelelő szerszámokat használja a kormányzási rendszer szereléséhez.
- Balesetek elkerülése érdekében körültekintően járjon el a kormányzási rendszer szerelésénél.
- Ne használja és ne üzemeltesse a kormányzási rendszert nem biztonságos időjárási körülmények között.
- Ne használja és ne üzemeltesse a kormányzási rendszert nem biztonságos terepviszonyok között.
- Csak a jármű vezetésére kiiktatott, tapasztalt és illetékes kezelő használhatja vagy üzemeltetheti a kormányzási rendszert.
- A munkatevékenység megkezdése előtt a kezelőnek elegendő ismerettel kell rendelkeznie a kormányzási rendszer biztonságos használatával kapcsolatban.
- A kormányzási rendszer szerelése során minden biztonsági óvintézkedést be kell tartani. Az esetlegesen meglazult, hiányzó vagy sérült alkatrészeket nem szabad használni.
- A kormányzási rendszer használata előtt minden funkció üzemképességét ellenőrizni kell a helyes működés érdekében. Kétségek esetén ne kockáztasson, hanem keresse a hivatalos forgalmazót vagy hívja a műszaki ügyfélszolgálatot.
- A kormányzási rendszer használata előtt ellenőrizze a Jelenlét-kapcsoló minden funkcióját a helyes működés érdekében.
- A kormányzási rendszer BE és KI kapcsolása csak az előírt helyes eljárással történhet.
- Ha bármelyik jármű vagy rendszerfunkció rendellenességet mutat – például túl nagy rezgések vagy zajok lépnek fel – akkor azonnal állítsa le a járművet és kapcsolja KI a kormányzási rendszert és keresse a hivatalos forgalmazót vagy hívja a műszaki ügyfélszolgálatot.
- A kormányzási rendszert karbantartása vagy tisztítása során teljesen KI kell kapcsolni és feszültségmentesíteni kell.
- A kormányzási rendszert használó kezelőnek minden biztonsági utasítást el kell olvasnia és tudomásul kell vennie, hogy megfelelően tudjon reagálni veszélyhelyzet esetén.
- Mindig a hivatalos forgalmazónak kell elvégeznie a kormányzási rendszer karbantartását és javítását.
- A kormányzási rendszer javítása vagy alkatrészcsereje során csak eredeti alkatrészeket szabad használni.
- A kormányzási rendszeren történő munkavégzés során a karbantartó és javító személyzetnek mindig viselnie kell a megfelelő személyi védőfelszerelést.
- A kormányzási rendszeren történő takarítás során a karbantartó személyzetnek mindig az ajánlott tisztító anyagokat kell használni.
- A kormányzási rendszer nem biztonságos állapotát vagy helyzetét jelenteni kell a hivatalos forgalmazónak vagy a műszaki ügyfélszolgálatnak.
- Nem helyezhetők el tárgyak a kormányzási rendszeren vagy a közelében.
- A kormányzási rendszer telepítése, kalibrálása és hangolása során a jármű kerekei balra és jobbra elfordulhatnak. Az ilyen lépések előtt győződjön meg róla, hogy senki és semmi ne legyen a kerekek közelében.
- A jármű ülését és kormánykereket helyezze normál üzemi helyzetbe és ellenőrizze, hogy a Mechanical Drive Unit (mechanikai meghajtó egység) (MDU) nem ütközik-e más kezelőszervekkel.
- A rendszer minden bekapcsolása során a kezelőnek el kell olvasnia és tudomásul kell vennie az Automatikus kormányzás felelősségi figyelmeztetését.
- Ha kérdések merülnek fel a kormányzási rendszer biztonságos használatával vagy a kézikönyvek utasításaival kapcsolatban, akkor azonnal keresse a hivatalos forgalmazót vagy a műszaki ügyfélszolgálatot.
- A kezelőnek figyelnie kell a jármű útvonalába eső tárgyakra. A kormányzási rendszer az akadályokat nem ismeri fel és nem kerüli ki.
- A kezelőnek a jármű vezetőülésében kell maradnia, amíg a kormányzási rendszer aktíválva van.
- A kormányzási rendszert csak a nyílt táblákon használja. A bármilyen fajtájú közútra történő kihajtás előtt kapcsolja KI a rendszert.

Felelősségi nyilatkozat A Novariant B.V. semmilyen módon nem tehető felelőssé semminemű kárért és/vagy balesetért, amely annak a gépnek az üzemzavarából ered, amelyre a telepítve van, a gép alkatrészeinek üzemzavarából, a gép jellemzőiből (pl. tréler) ered, harmadik fél által okozott interferenciá(k)ból vagy a kezelőnek a Novariant B.V. által előírt rendeltetésszerű használatától eltérő cselekedeteiből ered.

SZERZŐI JOGI NYILATKOZAT Az Ag Leader Technology szerzői jogvédelem alá helyezte (©2014) ennek az Összefoglaló útmutatónak a tartalmát valamint az INTEGRA és a VERSA rendszer üzemeltető programját. Az Ag Leader Technology előzetes beleegyezése nélkül nem készíthető másolat.

Nederlands (Dutch)

OnTrac3 systeem

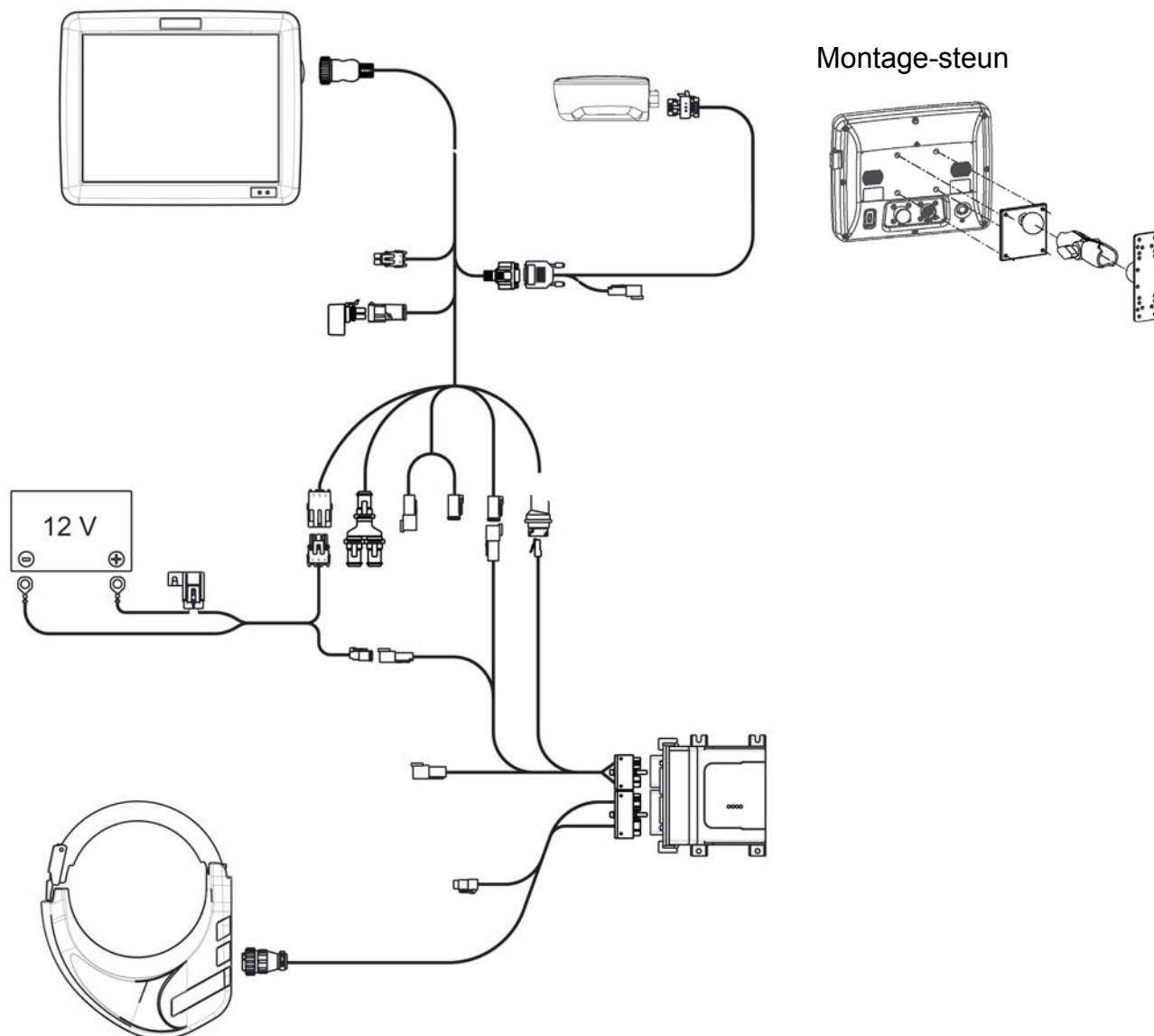

<p>Type zekering Steekzekering (ATO/ATC) 5 A 15 A Bedrijfsvoltage 9 - 16 V DC Max. nominaal stroombereik Ag Leader Integra4,0 A Versa2,5 A</p>	<p>Technische specificaties Overschrijd onderstaande specificaties niet:</p> <ul style="list-style-type: none">• Temperatuur in opslag: -20° tot +80°C• Temperatuur in bedrijf: -10° tot +70°C• Milieubeschermingsgraad: IP64• Geen aarding vereist• Gebruik 150 V isolatiegraad voor externe circuits
--	--

Veiligheidskennisgeving: Lees deze veiligheidsinstructies en de Gebruikershandleidingen grondig door en volg de instructies.

Besturingssysteem verwijst naar het OnTrac2 GPS Assisted Steering System en/of het OnTrac3 GPS Assisted Steering System en/of het ParaDyme-systeem en/of het GeoSteer-systeem.

- Alleen een operator die geheel bevoegd is om het voertuig te besturen, mag het besturingssysteem gebruiken.
- De operator mag de veilige snelheidslimiet voor het werktein niet overschrijden.
- De operator moet zich steeds bewust zijn van zijn/haar acties bij het gebruik van het besturingssysteem.
- Wanneer u het besturingssysteem installeert, mag u de componenten niet forceren omdat dit kan leiden tot schade aan de componenten.
- Volg altijd de instructies in de installatie-, gebruiks- en onderhoudshandleidingen.
- Alleen opgeleid personeel dient het besturingssysteem te installeren.
- Maak altijd een inventaris van de geleverde componenten om u ervan te verzekeren dat de juiste componenten aanwezig zijn. Gebruik nooit vervangende componenten. Gebruik alleen originele componenten.
- Als u vragen hebt over de veilige werking van het besturingssysteem of de instructies in de handleidingen, neemt u onmiddellijk contact op met uw geautoriseerde dealer of de technische ondersteuning.
- Gebruik altijd het juiste gereedschap voor de installatie van het besturingssysteem.
- Wees voorzichtig bij de installatie van het besturingssysteem om letsels te voorkomen.
- Gebruik of bedien het besturingssysteem niet bij onveilige weersomstandigheden.
- Gebruik of bedien het besturingssysteem niet als het terrein onveilig is.
- Alleen een opgeleide, ervaren of bevoegde operator mag het besturingssysteem gebruiken of bedienen.
- Voordat de operator het besturingssysteem gebruikt, moet hij/zij over voldoende kennis beschikken om de systemen op een veilige manier te bedienen.
- Alle voorzorgsmaatregelen op het gebied van veiligheid moeten goed begrepen zijn bij de installatie van het besturingssysteem. Losse, ontbrekende of beschadigde onderdelen dienen niet te worden gebruikt.
- Ga voor het gebruik van het besturingssysteem na indien alle functies zijn gecontroleerd om de juiste werking ervan te verzekeren. Neem geen risico's bij twijfel: neem altijd contact op met uw geautoriseerde dealer of de technische ondersteuning.
- Controleer voor het gebruik van het besturingssysteem alle functies van de Aanwezigheidsschakelaar voor de operator om u ervan te verzekeren dat deze schakelaar juist werkt.
- Het in- en uitschakelen van het besturingssysteem moet gebeuren met behulp van de juiste, voorgeschreven procedures.
- Als het voertuig of het systeem niet zoals verwacht werkt (bijvoorbeeld buitensporige trillingen of overmatig geluid), stopt u onmiddellijk het voertuig, schakelt u het besturingssysteem UIT en neemt u contact op met uw geautoriseerde dealer of de technische ondersteuning.
- Bij het onderhoud of de reiniging van het besturingssysteem moet het systeem volledig uitgeschakeld zijn en spanningsloos zijn.
- De operator van het besturingssysteem moet alle veiligheidsinstructies lezen en begrijpen zodat hij/zij op gepaste wijze kan reageren in een noodgeval.
- De geautoriseerde dealer moet altijd onderhoudswerkzaamheden aan of reparaties van het besturingssysteem uitvoeren.
- Tijdens de reparatie of de vervanging van componenten van het besturingssysteem mogen alleen originele componenten worden gebruikt.
- De operator of het onderhoudspersoneel moet altijd de juiste beschermingsuitrusting dragen bij werkzaamheden aan het besturingssysteem.
- Onderhoudspersoneel moet altijd de aanbevolen reinigingsmiddelen en -accessoires gebruiken bij de reiniging van het besturingssysteem.
- Onveilige omstandigheden of situaties met het besturingssysteem moeten aan uw geautoriseerde dealer of de technische ondersteuning worden gemeld.
- Er mogen geen objecten op of in de buurt van het besturingssysteem worden geplaatst.
- Tijdens de installatie, kalibratie en afstelling van het besturingssysteem draaien de wielen van het voertuig mogelijk naar links en rechts. Verzekert u ervan dat er zich geen personen of obstakels in de buurt van de wielen bevinden voordat u verder gaat.
- Zet de stoel en het stuur van het voertuig in de normale werkstand en controleer of de OnTrac2 Mechanical Drive Unit (MDU) geen bedieningen hindert.
- De operator moet de Aansprakelijkheidsverklaring van de Automatische sturing lezen en bevestigen telkens als het systeem wordt ingeschakeld.
- Als u vragen hebt over de veilige werking van het besturingssysteem of de gebruiksaanwijzing, neemt u onmiddellijk contact op met uw geautoriseerde dealer of de technische ondersteuning.
- De operator moet letten op obstakels in het pad van het voertuig. Het besturingssysteem kunnen/kan geen obstakels identificeren of vermijden.
- De operator mag de operatorstoel in het voertuig niet verlaten terwijl het besturingssysteem is ingeschakeld.
- Gebruik alleen het besturingssysteem in een open veld. De systemen moet uitgeschakeld zijn wanneer het voertuig zich op de weg begeeft.

Aansprakelijkheidsverklaring Novariant B.V. kan op geen enkele manier verantwoordelijk worden gehouden of aansprakelijk worden gesteld voor enige schade en/of ongelukken die plaatsvinden door de slechte werking van de machine waarop het is geïnstalleerd, slechte werking van machinecomponenten, machineattributen (bijv. trailers), tussenkomst(en) van derden of handelingen van de operator buiten het bestemde gebruik zoals voorgeschreven door Novariant B.V.

COPYRIGHTKENNISGEVING Ag Leader Technology heeft het auteursrecht (©2014) op de inhoud van deze publicatie en het besturingsprogramma voor de INTEGRA- en VERSA-systemen. Zonder de uitdrukkelijke toestemming van Ag Leader Technology mogen geen kopieën worden gemaakt.

Polski (Polish)

System OnTrac3

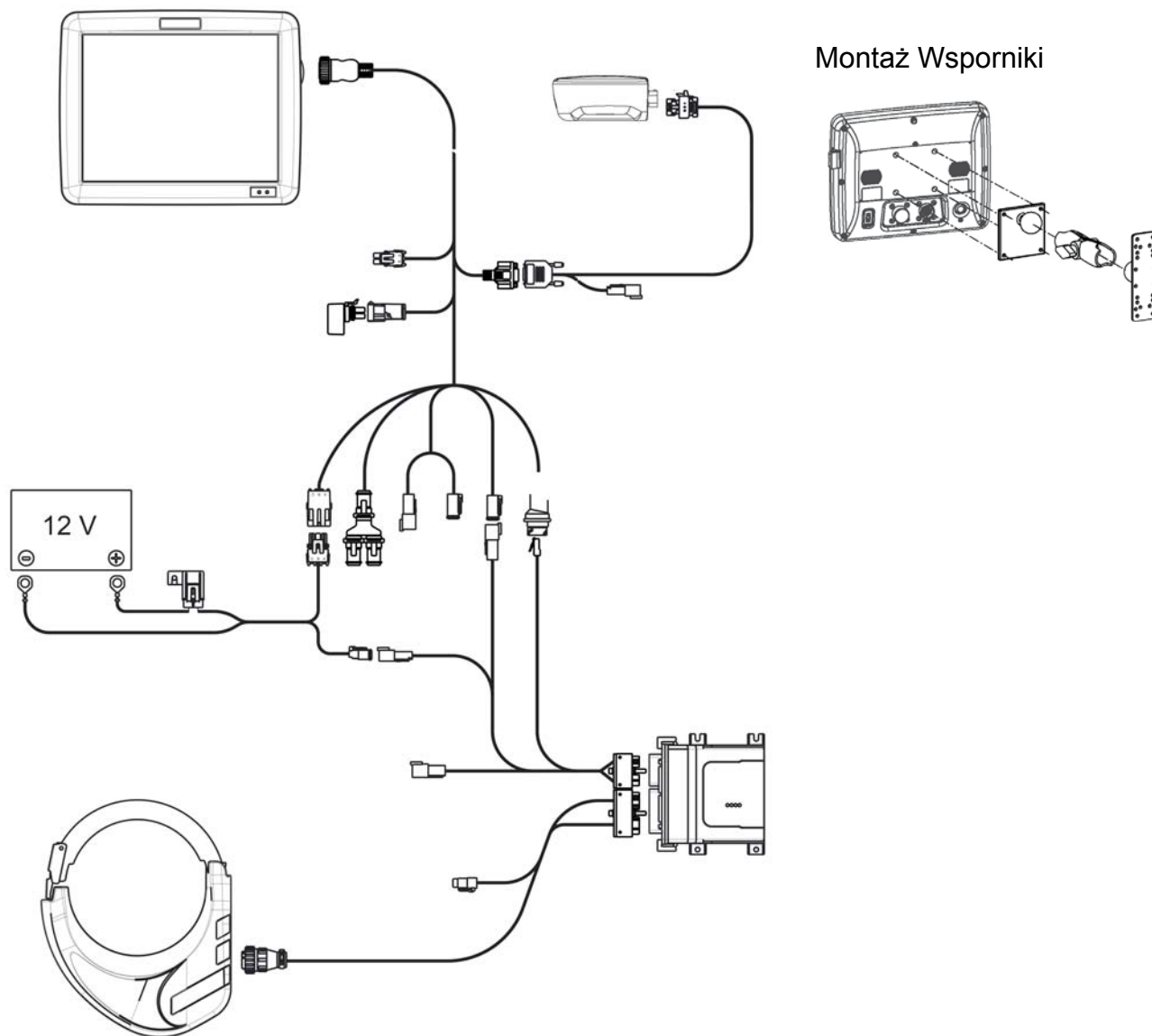

Rodzaj bezpiecznika

Styl noża (ATO/ATC)

Napięcie 5 A

Napięcie 15 A

Napięcie robocze

9-16 V DC

Maks prąd znamionowy

Ag Leader Integra4.0 A

Versa2.5 A

Specyfikacje techniczne

Nie wykraczać poza poniższe dane:

• Temperatura przechowywania:

-20°C do +80°C

• Temperatura działania:

-10°C do +70°C

• Klasyfikacja ze względu na ochronę środowiska:
IP64

• Nie wymagane uziemienie ochronne

• Używa maksymalnej klasy izolacyjności 150V do zewnętrznych obwodów.

Komunikat dotyczący bezpieczeństwa: Zapoznaj się z niniejszymi instrukcjami bezpieczeństwa oraz podręcznikiem użytkownika i postępuj zgodnie z nimi.

System sterowania odnosi się do wspomaganego systemu sterowania OnTrac2 GPS i/lub wspomaganego systemu sterowania OnTrac3 GPS i/lub systemu ParaDyme i/lub systemu GeoSteer.

- Wyłącznie operator upoważniony do kierowania pojazdem może używać systemu sterowania.
- Operator nie może przekraczać bezpiecznej prędkości jazdy na obszarze, na którym pracuje pojazd.
- Operator musi być zawsze świadomy swoich czynności przy obsłudze systemu sterowania.
- Przy instalacji systemu sterowania nie forsować elementów składowych, gdyż mogą zostać uszkodzone.
- Zawsze przestrzegaj instrukcji instalacji, obsługi i konserwacji.
- Wyłącznie przeszkolony personel powinien instalować system sterowania.
- Zawsze upewnij się, że dostarczono właściwe elementy dokładnie je sprawdzając. Nigdy nie używaj zastępczych części. Zawsze używaj oryginalnych części.
- W przypadku jakichkolwiek pytań dotyczących bezpiecznego działania systemu sterowania lub instrukcji obsługi, proszę skontaktować się natychmiast z upoważnionym sprzedawcą lub punktem obsługi klienta.
- Zawsze używaj właściwych narzędzi do instalacji systemu sterowania.
- Aby uniknąć obrażeń, zawsze zachowaj ostrożność przy instalacji systemu sterowania.
- Nie używaj i nie włączaj systemu sterowania przy niebezpiecznych warunkach pogodowych.
- Nie używaj i nie włączaj systemu sterowania na niebezpiecznym terenie.
- Wyłącznie przeszkolony, doświadczony lub upoważniony operator może obsługiwać lub używać systemu sterowania.
- Przed rozpoczęciem obsługi systemu sterowania operator musi posiadać wystarczającą wiedzę na temat bezpiecznego działania tych systemów.
- Przy instalacji systemu sterowania należy zapoznać się i zrozumieć wszystkie środki bezpieczeństwa. Nie należy używać systemów, jeśli któraś z części jest zgubiona, brakująca lub uszkodzona.
- Należy sprawdzić i skontrolować, czy wszystkie funkcje systemu sterowania działają prawidłowo przed rozpoczęciem pracy. W przypadku wątpliwości nie podejmuj ryzyka – skontaktuj się z upoważnionym sprzedawcą lub punktem obsługi klienta.
- Należy sprawdzić, czy wszystkie funkcje Przełącznika obecności operatora działają prawidłowo przed rozpoczęciem pracy w systemie sterowania.
- Należy włączać i wyłączać system sterowania przestrzegając właściwych podanych procedur.
- Jeśli jakaś funkcja pojazdu lub systemu nie działa właściwie, np. w przypadku pojawienia się nadmiernych drgań lub hałasu, natychmiast zatrzymaj pojazd, wyłącz system sterowania i skontaktuj się z upoważnionym sprzedawcą lub punktem obsługi klienta.
- Należy wyłączyć całkowicie system sterowania przy ich konserwacji lub czyszczeniu i upewnić się, że nie są pod napięciem.
- Operator systemu sterowania powinien przeczytać ze zrozumieniem wszystkie instrukcje bezpieczeństwa, tak aby móc właściwie zareagować w przypadku awarii.
- Upoważniony sprzedawca musi zawsze wykonać czynności konserwacji lub naprawy systemu sterowania.
- Należy używać wyłącznie oryginalnych części podczas naprawy lub wymiany części systemu sterowania.
- Operator lub personel odpowiedzialny za konserwację powinien zawsze nosić właściwą odzież ochronną przy pracy przy systemie sterowania.
- Personel odpowiedzialny za konserwację powinien zawsze używać zalecanych środków i akcesoriów czyszczących przy czyszczeniu systemu sterowania.
- Informacje o niebezpiecznych warunkach lub sytuacjach zaistniałych przy systemie sterowania należy przekazać do upoważnionego sprzedawcy lub punktu obsługi klienta.
- Nie należy umieszczać żadnych przedmiotów w obrębie systemu sterowania.
- Podczas instalacji, kalibracji i regulacji systemu sterowania koła pojazdu mogą kręcić się w prawo i w lewo. Przed rozpoczęciem działań upewnij się, że w pobliżu kół nie ma żadnych postronnych osób lub przedmiotów.
- Ustaw fotel w pojeździe oraz kierownicę w normalnej pozycji działania i sprawdź, czy Jednostka kierująca (MDU) nie zakłóca działania innych kontrolerek.
- Operator musi przeczytać i przyjąć do wiadomości informacje o zakresie odpowiedzialności automatycznego sterowania za każdym włączeniem systemu.
- W przypadku jakichkolwiek pytań dotyczących bezpiecznego działania systemu sterowania lub instrukcji obsługi, proszę skontaktować się z upoważnionym sprzedawcą lub punktem obsługi klienta.
- Operator musi zwracać uwagę na ewentualne przeszkody na trasie pojazdu. System sterowania nie może identyfikować ani unikać przeszkód.
- Operator musi pozostać w swoim fotelu w pojeździe, kiedy system sterowania jest włączony.
- Używaj systemu sterowania wyłącznie na otwartym polu. Systemy muszą być wyłączone, kiedy pojazd znajduje się na drodze.

Informacje o zakresie odpowiedzialności Novariant B.V. nie może być pociągnięty do odpowiedzialności za uszkodzenia i/lub wypadki powstałe na skutek niewłaściwego działania maszyny, na której zostały zainstalowane, niewłaściwego działania części maszyny, oprzyrządowania maszyn (np. przyczep), ingerencji osób trzecich lub czynności operatora, które nie wchodzą w zakres stosowania zalecanego przez Novariant B.V.

INFORMACJA O PRAWACH AUTORSKICH Ag Leader Technology chroni prawem autorskim (©2014) zawartość niniejszego dokumentu i programu obsługi dla systemów INTEGRA i VERSA. Wykonywanie reprodukcji bez uzyskania wcześniejszej zgody Ag Leader Technology jest zabronione.

